

QM-Height

SERIES 518 — High Precision ABSOLUTE Digital Height Gage

FEATURES

- Newly developed high accuracy and high resolution ABSOLUTE linear encoder for position detection.
- Easy reference icon keys.
- Possible to measure inside/outside diameter via unique process (detect the circle apex and process by tracing measurement).
- Various types of optional probes are available.
- Large size LCD with back light.
- GO/±NG judgment is performed by setting the upper and lower tolerances. If a judgment result is out of tolerance, the display backlighting changes from green to red, so tolerance judgment can be made at a glance.
- Slider elevation knob (for travel) / wheel (for measurement).
- With SPC and RS-232C output.



Technical Data

Measuring range: 0 - 18.3" or 0 - 28.1"
0 - 465mm or 0 - 715mm
Slider stroke: 14" / 350mm or 24" / 600mm
Resolution: 0.001 / 0.005mm or 0.001 / 0.005mm / .00005" / .0001" / .0002"
Accuracy at 20°C: Refer to the list of specifications
Guiding method: Roller bearing
Drive method: Manual
Length standard: ABSOLUTE electrostatic capacitance type linear encoder
Measuring force: 1.6±0.5N
Display: LCD
Power supply: AC adapter (optional) / battery (LR6x4)
Battery operation time: Approx. 260 hours (approx. 6 hours when using back light)

SPECIFICATIONS

	Inch/Metric	
Order No.	518-221	518-223
Range	0 - 14" (0 - 350mm)	0 - 24" (0 - 600mm)
Resolution	.00005", .0001", .0002" / 0.001mm, 0.005mm	
Accuracy	± (.00011 + .0002xL / 40)"	
Repeatability	.00007" (2s)	
Display	LCD	
Functions	Zero setting, +/- switching, Presetting, Data hold, Probe tip diameter compensation, inch/mm conversion (Inch/Metric model only), Data output	
Perpendicularity	.0003"	.0005"
Measuring force	1.6 ± 0.5N	
Data output	SPC, RS-232C	
Power supply	AC adapter (optional accessory) / Battery (LR6x4)	
Battery Life	Approx. 800 Hrs. (when backlight is not used)	
	Approx. 260 Hrs. (When backlight is used in the power saving mode)	
	Approx. 6 Hrs. (When backlight is used in the Full-Time Turn-On mode)	
Standard Accessories	ø5mm stepped probe (05HZA148) 4 pcs. AA Alkaline Batteries (LR6)	
Users Manual	99MAF017B	
Mass	22kg	27kg



GO



±NG

Optional Accessories

- 12AAC072:** Depth probe
- 12AAA792:** Dial indicator (ø8mm stem) holder
- 12AAA837:** Dial indicator (ø3/8" stem) holder
- 12AAA793:** Probe extension holder (85mm/3.3")
- 12AAF667:** ø2mm ruby ball probe
- 957261:** ø2mm ball probe
- 957262:** ø3mm ball probe
- 957263:** ø4mm ball probe
- 12AAB552:** ø10mm ball probe, L=55mm
- 12AAF670:** ø5mm disk probe
- 12AAF671:** ø10mm disk probe
- 957264:** ø14mm disk probe
- 957265:** ø20mm disk probe
- 12AAA788:** ø4mm ball offset probe
- 12AAF394:** ø5mm ball offset probe
- 12AAA789:** ø6mm ball offset probe
- 226116:** Test indicator (ø6mm stem) adapter
- 05HZA173:** Scriber
- 264-504-5A:** DP-1VR
- 936937:** SPC cable (40" / 1m)
- 965014:** SPC cable (80" / 2m)
- 526688A:** AC adapter (120V)

Circle pitch measurement

The length A, B, C and D can be determined by measuring circles 1 to 3 once each, using the memory of measuring data together with the calculation function. (A maximum of nine circle measurement data can be saved.)

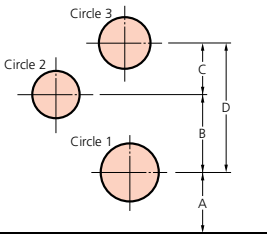

Maximum/minimum and displacement measurement

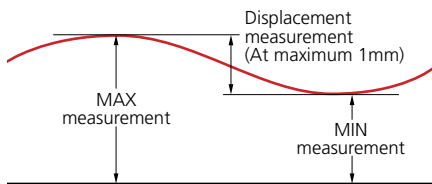

Height measurement

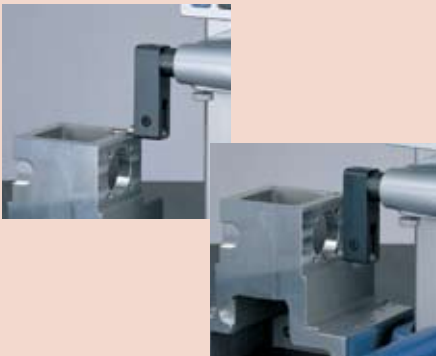

Inside diameter measurement

DIMENSIONS

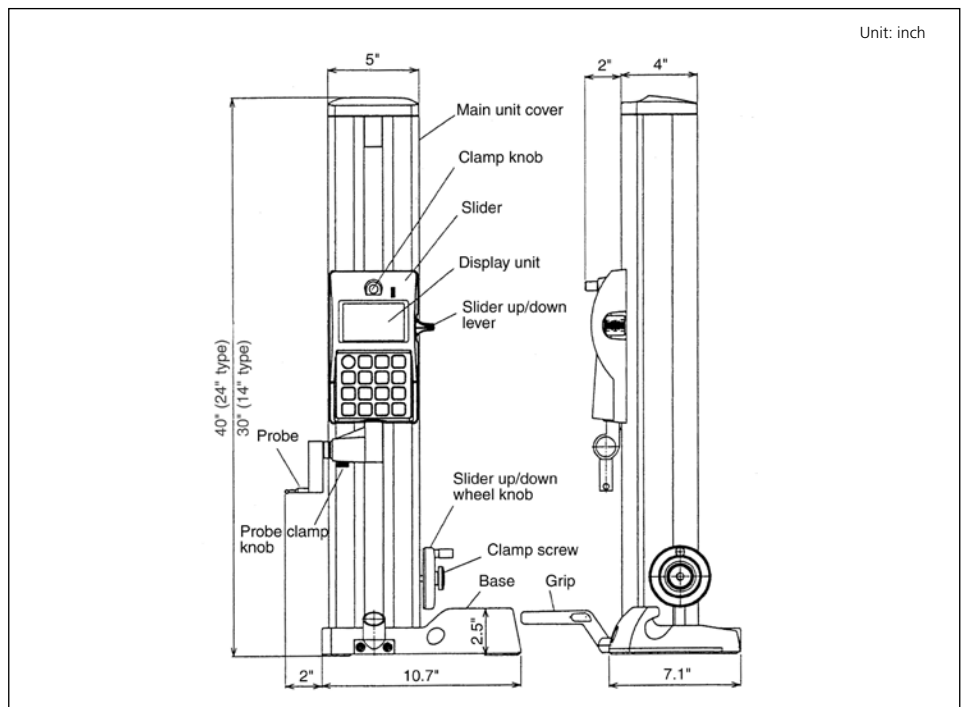

Unit: inch

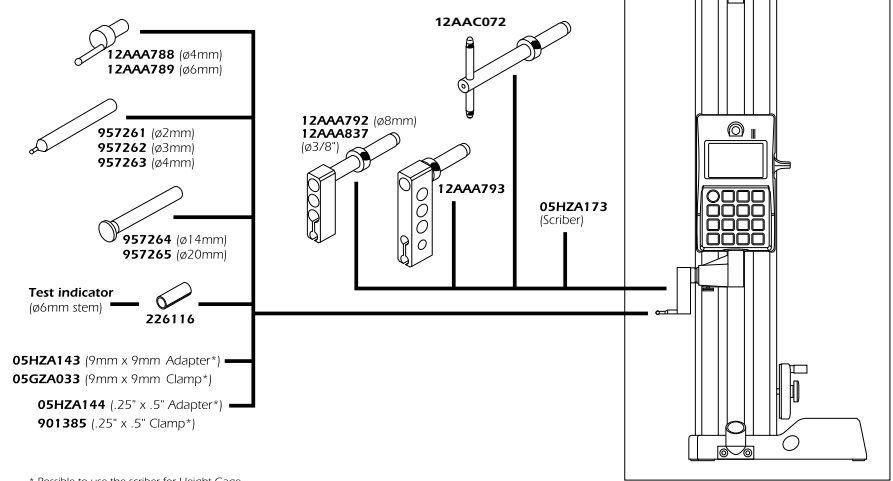

* Possible to use the scriber for Height Gauge.