



 Operating instructions

Digimar 816 CL

Height Measuring Instrument

3759587-en

Version 1.8

Mahr GmbH
Standort Esslingen
Reutlinger Str. 48, 73728 Esslingen
Tel. +49 711 9312-600, Fax +49 711 9312-756
mahr.es@mahr.de, www.mahr.com

Safety Instructions

This height measuring instrument employs the state-of-the-art technology and complies with recognized safety regulations. Nevertheless, the operator or third parties can risk life or limb if the following safety instructions are not strictly observed!

1. All operators must read the safety instructions and the enclosed operating instructions thoroughly **before** putting the height measuring instrument into operation.
2. This height measuring instrument must only be used if it is in **perfect technical condition**. Any malfunctions, particularly those impairing safety, must be eliminated immediately.
3. This height measuring instrument must only be used for the intended purposes and in accordance with the operating instructions provided. The operating instructions must be stored in the immediate proximity of the site where the height measuring instrument is being used.
4. Before connecting the height measuring instrument to the mains, make sure that the voltage specified on the rating plate agrees with the local mains voltage. If the two voltages do not agree, do not connect the height measuring instrument under any circumstances!
5. The height measuring instrument may only be connected to socket outlets with properly grounded contacts. Extension cables must meet the stipulations of the local electrical standards or similar.
6. Any modification or manipulation of the height measuring instrument requires the express written approval of Mahr GmbH and must be carried out by qualified personnel. Unauthorized opening of the height measuring instrument and unauthorized intervention invalidates the warranty and frees Mahr GmbH from any liability. Before opening the height measuring instrument, switch off the unit and pull the mains plug from the mains socket outlet.
7. Before cleaning the height measuring instrument, pull the mains plug from the mains socket outlet. Never let any liquids penetrate the height measuring instrument! Do not use cleaning agents that are harmful to plastics.
8. If a fuse needs replacing, only a fuse of the **same** type - in terms of amperage and blow characteristics - may be used. When exchanging fuses, follow the procedure outlined in the operating instructions.
9. All relevant safety and accident prevention regulations must be complied with. Your safety expert will provide further instructions based on local circumstances and in-house guidelines.
10. Do not operate the height measuring instrument in rooms filled with explosive gases. An electrical spark could trigger an explosion.
11. Never move the height measuring instrument to the edge of the base plate at speed. The air cushion carrying the column will be unable to dissipate quickly enough to decelerate the height measuring instrument before it reaches the edge. This could cause the height measuring instrument to fall off the base plate and harm the operator.
12. Do not short-circuit the battery; this could result in a fire or the risk of an explosion!



**When returning the height measuring instrument, please ONLY ship the height measuring instrument in its original carrying case and on an appropriate pallet!
Failure to do this will invalidate the warranty!**

Restriction of the use of certain Hazardous Substances (RoHS):

Old electronic height measuring instruments which were brought from Mahr after the 23. March 2006 can be returned to us for disposal. We will dispose/recycle our products without causing any harm or damage to the environment in accordance to the EU-Directives 2002/95/EC RoHS (the Restriction of the use of certain Hazardous Substances) and 2002/96/EC WEEE (Waste Electrical and Electronic Equipment) as well as German National - Electrical and Electronic Equipment Act, FRG

Table of contents

1.	Delivery and setting up	
1.1	Scope of supply	5
1.2	Unpacking	6
1.3	Description and explanation of the height measuring instrument	13
1.3.1	Height measuring instrument	13
1.3.2	Keypad	14
1.3.3	Display	14
1.3.4	Description of the symbols	15
1.3.4.1	Keypad symbols	15
1.3.4.2	Function key symbols	15
1.3.4.3	Symbols - display	17
2.	Commissioning / First steps	
2.1	Switching ON	18
2.2	Calibrating a probe	19
2.3	Moving / positioning the height measuring instrument	19
2.4	First measurement	20
2.4.1	Contacting a surface from above	20
2.4.2	Measuring a bore	20
2.5	Switching OFF	21
3.	Operation and measurement	
3.1	Standard calibration / calibrate a probe	22
3.1.1	Calibrating a probe using a groove	22
3.1.2	Calibrating a probe using a ledge	23
3.1.3	Calibrate with a taper probe	24
3.1.4	Deviations caused by calibration	24
3.2	Zero points	25
3.2.1	Set the zero point on the base plate	25
3.2.2	Entering a PRESET value	25
3.2.3	Expanding the measuring range	26
3.3	Basic measuring functions	27
3.3.1	Contacting from above	27
3.3.2	Contacting from below	27
3.3.3	Measuring a groove	27
3.3.4	Measuring a bore	28
3.4	Function keys	29
3.4.1	Calculating a distance	29
3.4.2	Calculating symmetry	29
3.4.3	Relative / Absolute zero point	30
3.4.4	FTC-Function key	30
3.4.4.1	MIN/MAX-Function	31
3.4.4.2	Measuring a ledge	32
3.4.4.3	Measuring a shaft	32
3.4.4.4	Contacting a bore from below	33
3.4.4.5	Contacting a bore from above	33
3.4.4.6	Center of a bore / display the position	33
3.4.4.7	Contacting a shaft from below	34
3.4.4.8	Contacting a shaft from above	34

4.	Delete, save and print measured values	
4.1	Delete	35
4.1.1	Delete all measurements	35
4.1.2	Delete an individual measurement	35
4.1.3	Delete an entry	36
4.1.4	Return	36
4.2	Print measured values	36
4.2.1	Print with a MSP 2 printer	36
4.3	Send measured values	36
5.	Menu - Basic settings	
5.1	Data transmission	37
5.1.1	Basic settings / Symbols	37
5.1.2	Interfaces	38
5.1.3	Send a series of measured data	39
5.1.4	Select measured data	40
5.1.5	Create a record head data	40
5.2	Resolution	41
5.3	Acoustic signal	42
5.4	Contacting speed	42
5.5	Standstill-time	42
5.6	Contacting parameter (probe lift)	43
5.7	Time / date	43
5.8	Switching the unit of measurement mm / inch	43
5.9	Display	44
5.10	Factory settings	44
5.11	Service / Customer service (reserved only for Mahr)	45
5.12	Select a list of measurements	45
5.13	Software update	45
6.	Measuring program	
6.1	Create and save a measuring program	47
6.2	Start a measuring program	48
7.	Additional functions	
7.1	Data transmission with MarCom	49
7.2	Temperature compensation	50
7.2.1	Display the temperature	50
7.2.2	Active temperature compensation	50
8.	Self-help, maintenance and care	
8.1	Maintenance and care	52
8.1.1	Cleaning the height measuring instrument	52
8.1.2	Charging the batteries	52
8.1.3	Exchanging the batteries	53
8.2	Troubleshooting	54
9.	Accessories	55
10.	Technical data	59
11.	Alphabetical index	60
12.	Declaration of conformity	62

1. Delivery and setting up

1.1 Scope of supply

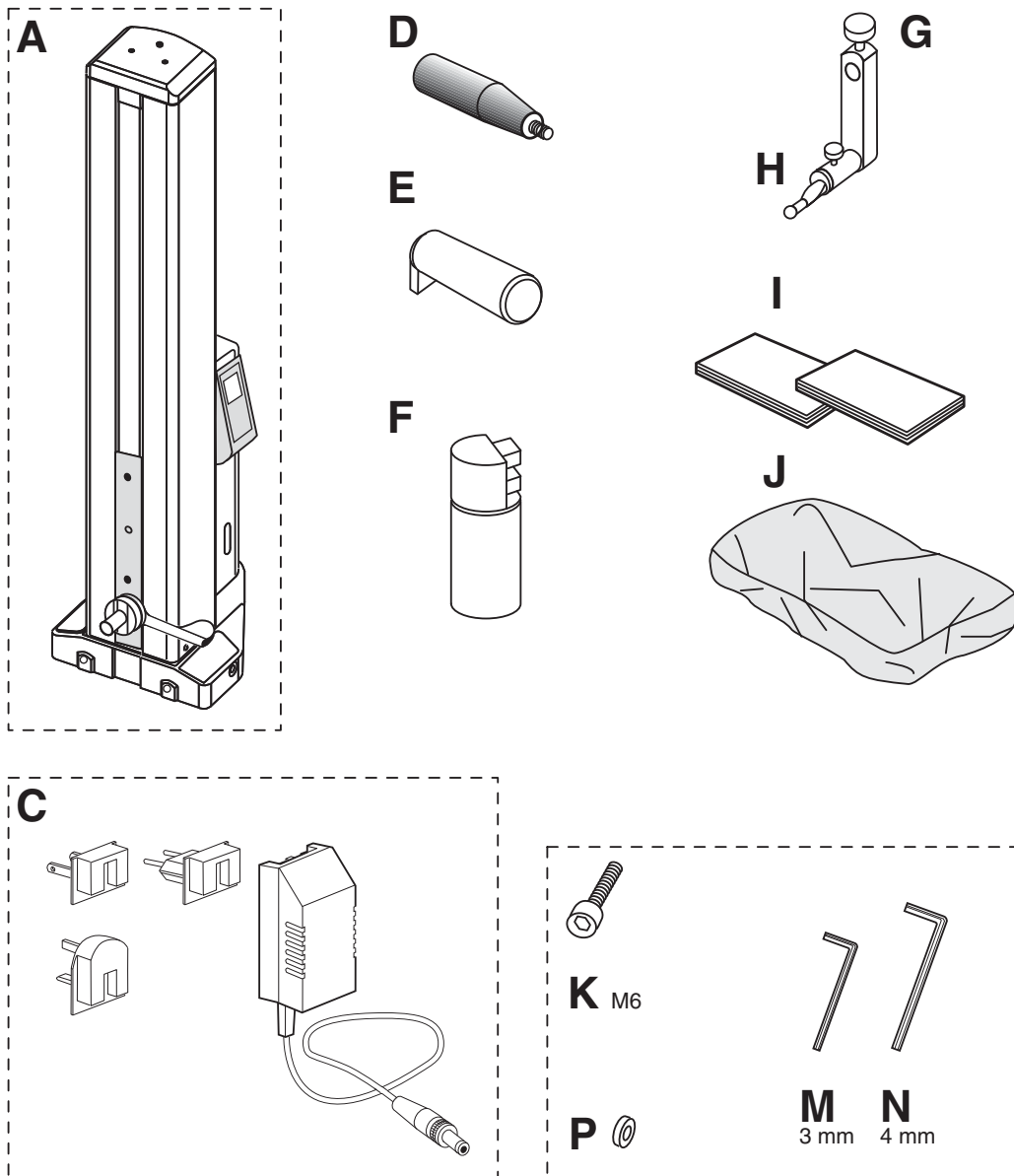

1.2 Unpacking

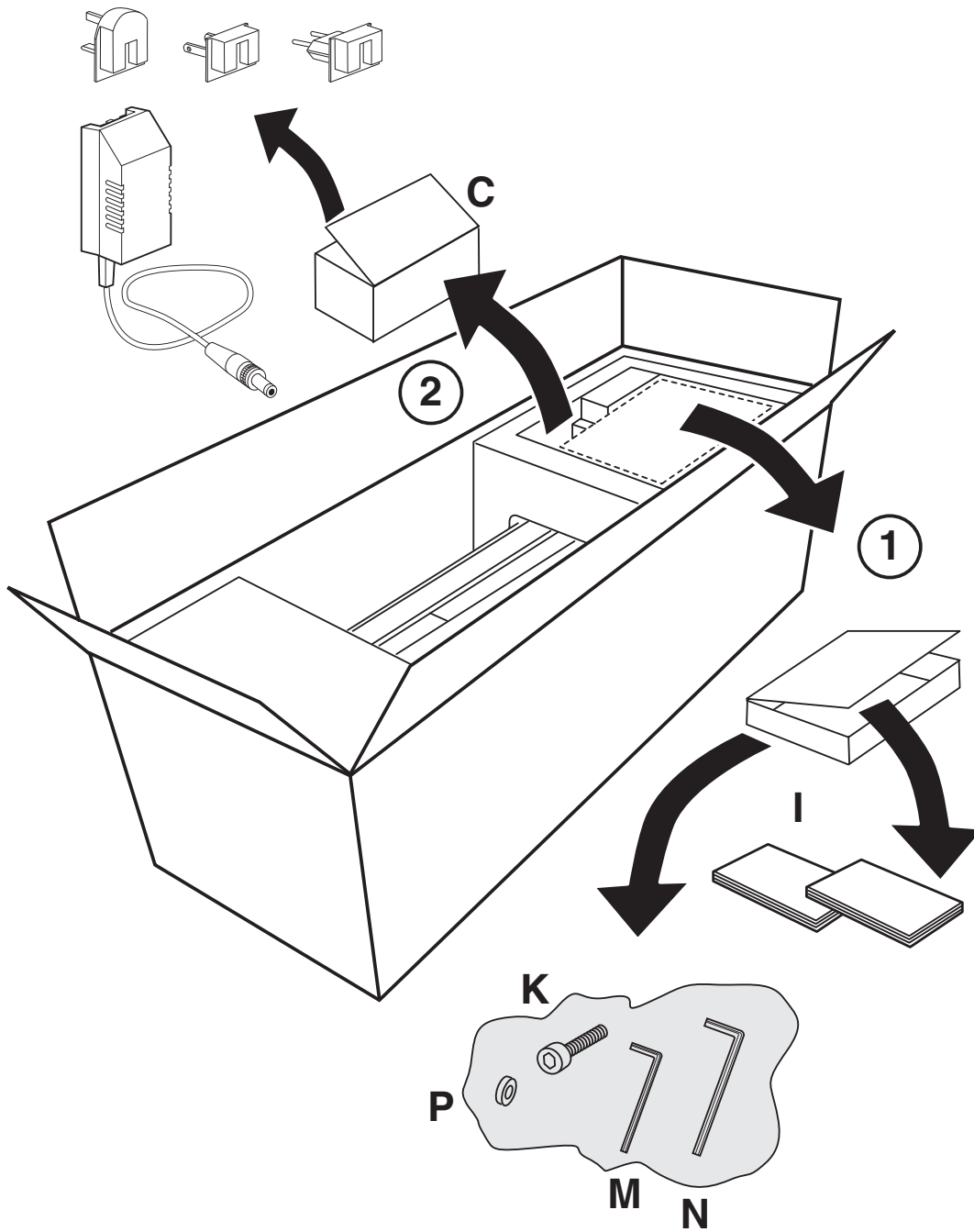

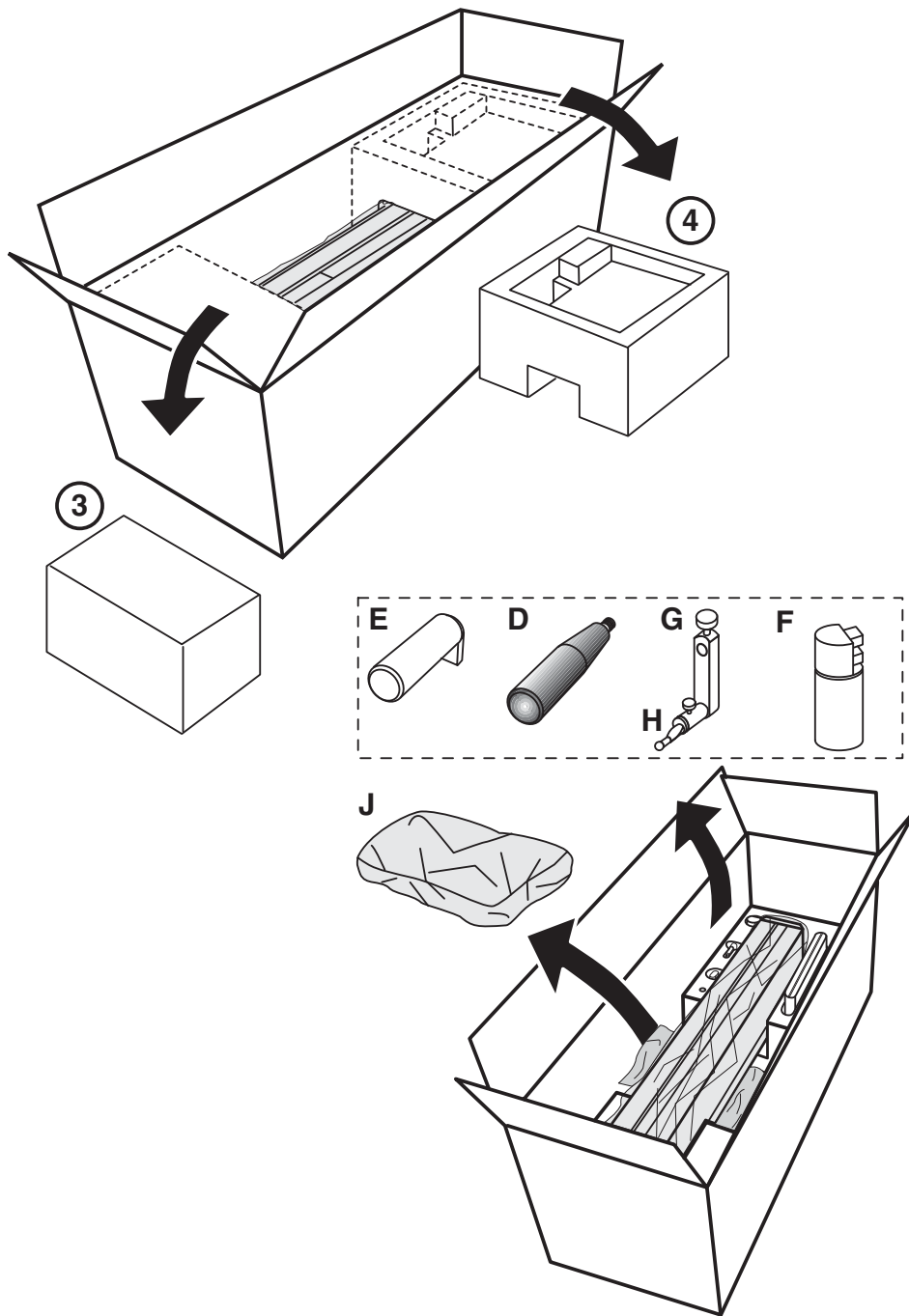

	350 mm	25 kg
	600 mm	30 kg



5

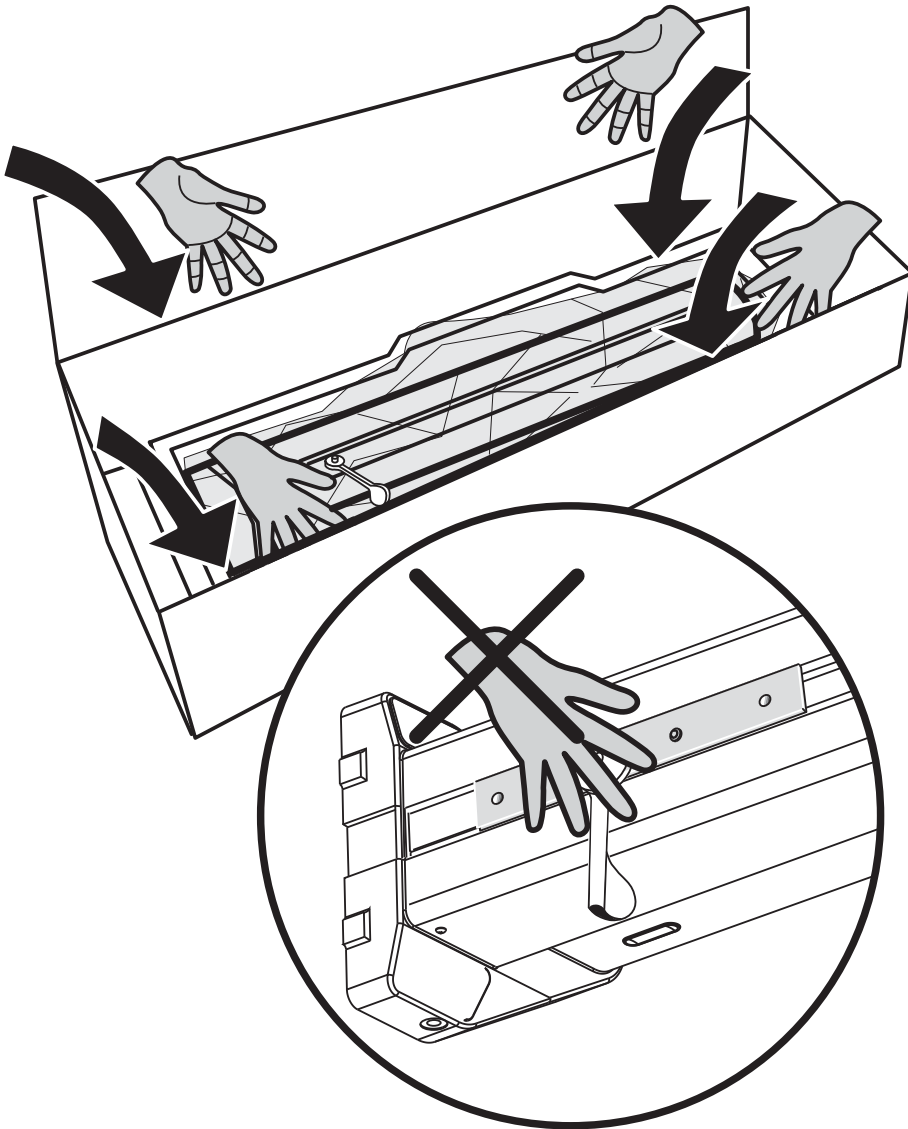

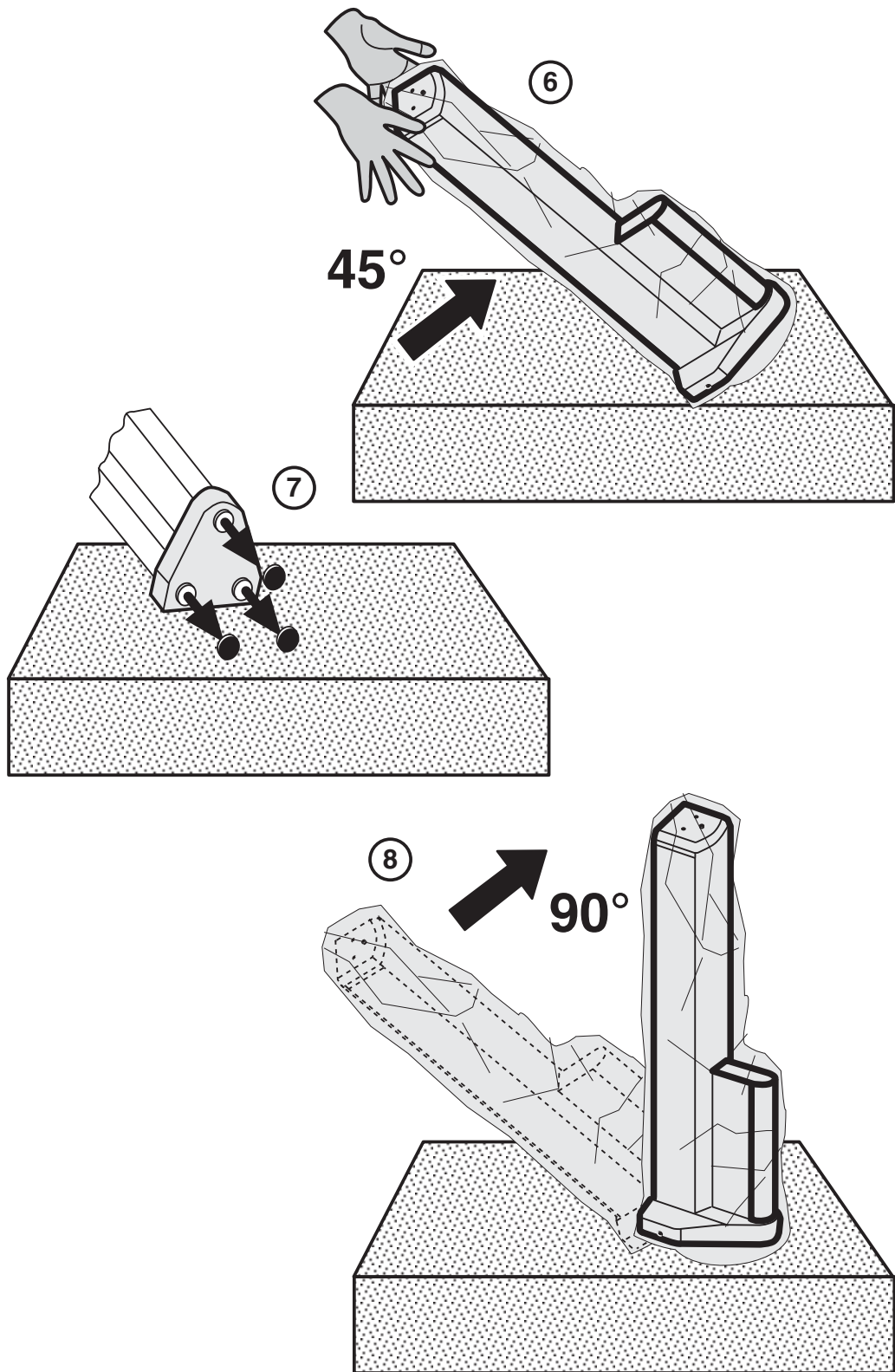

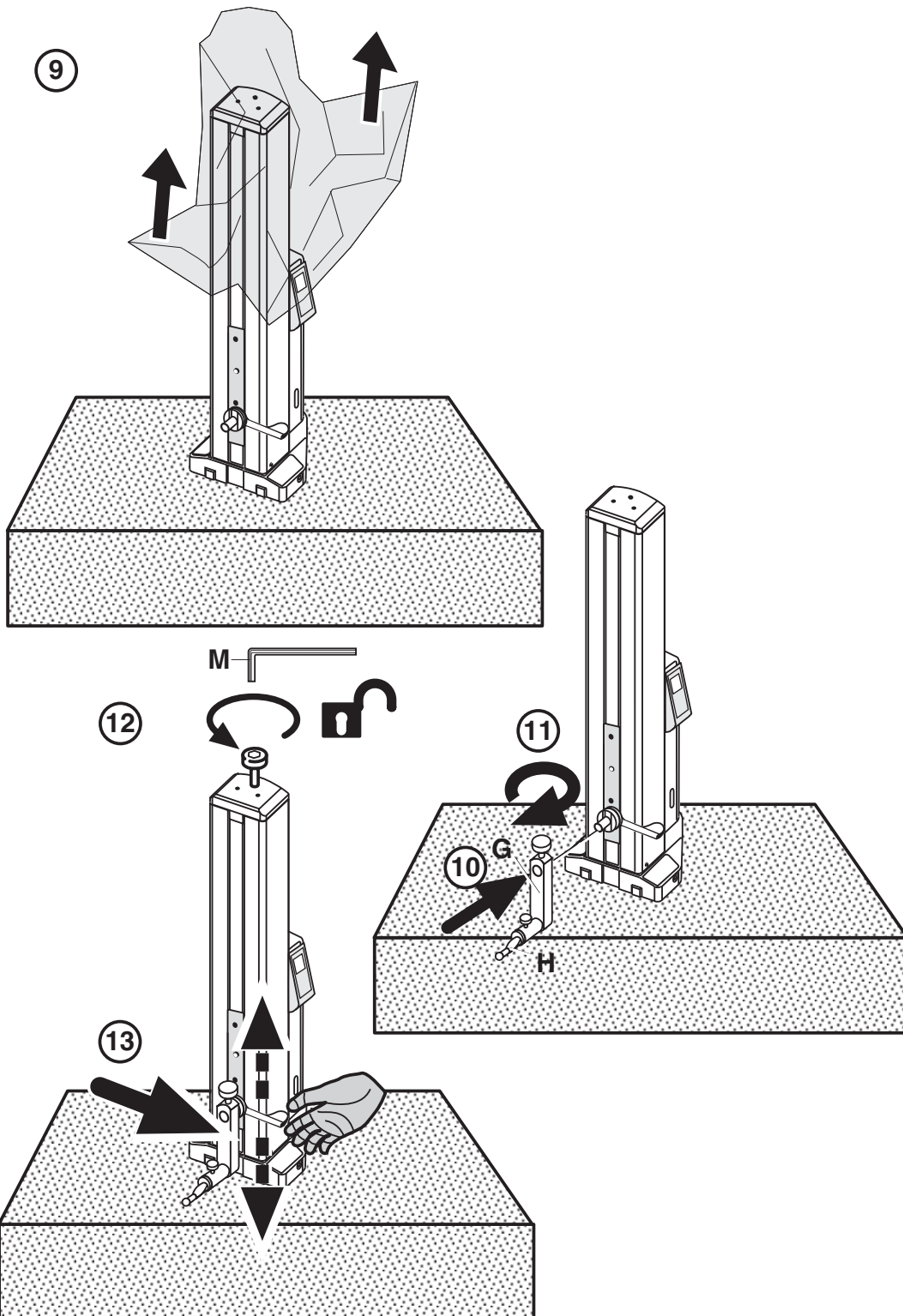

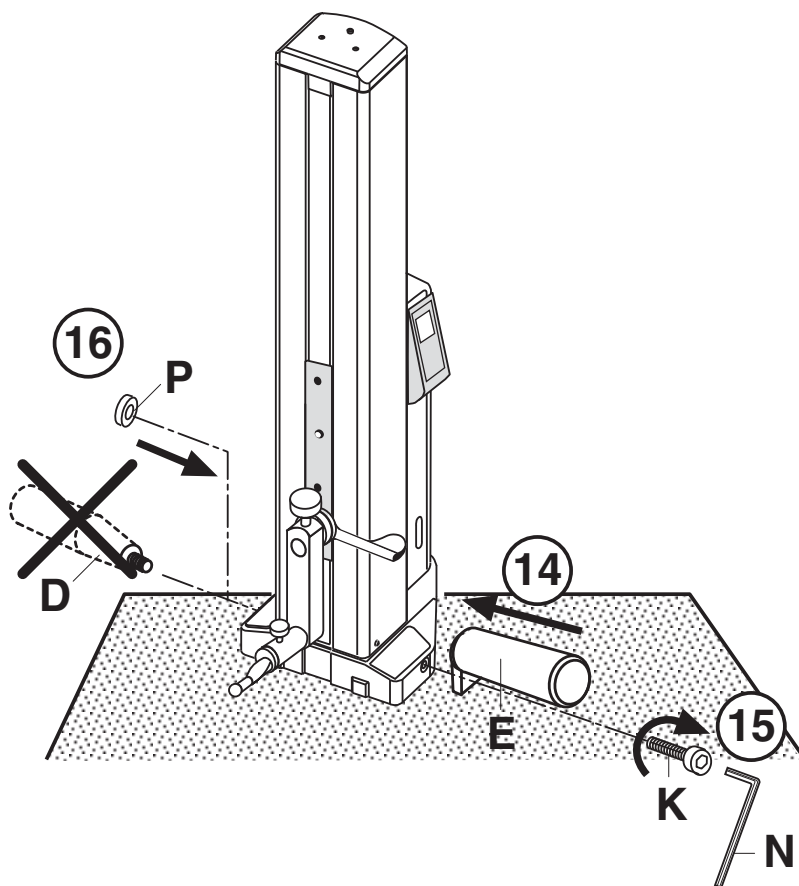

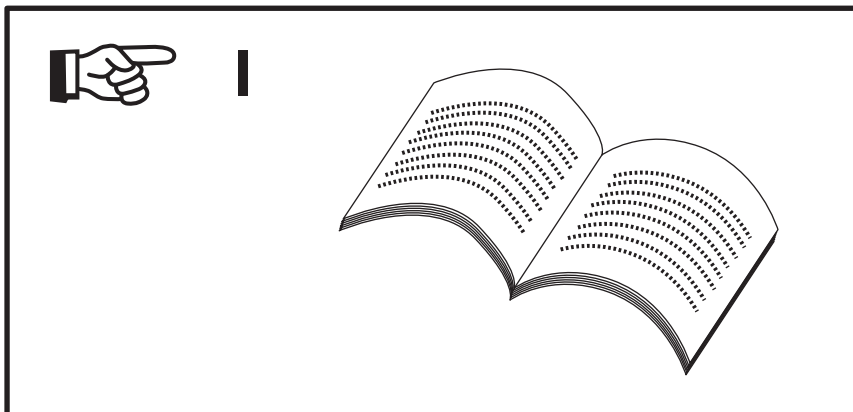
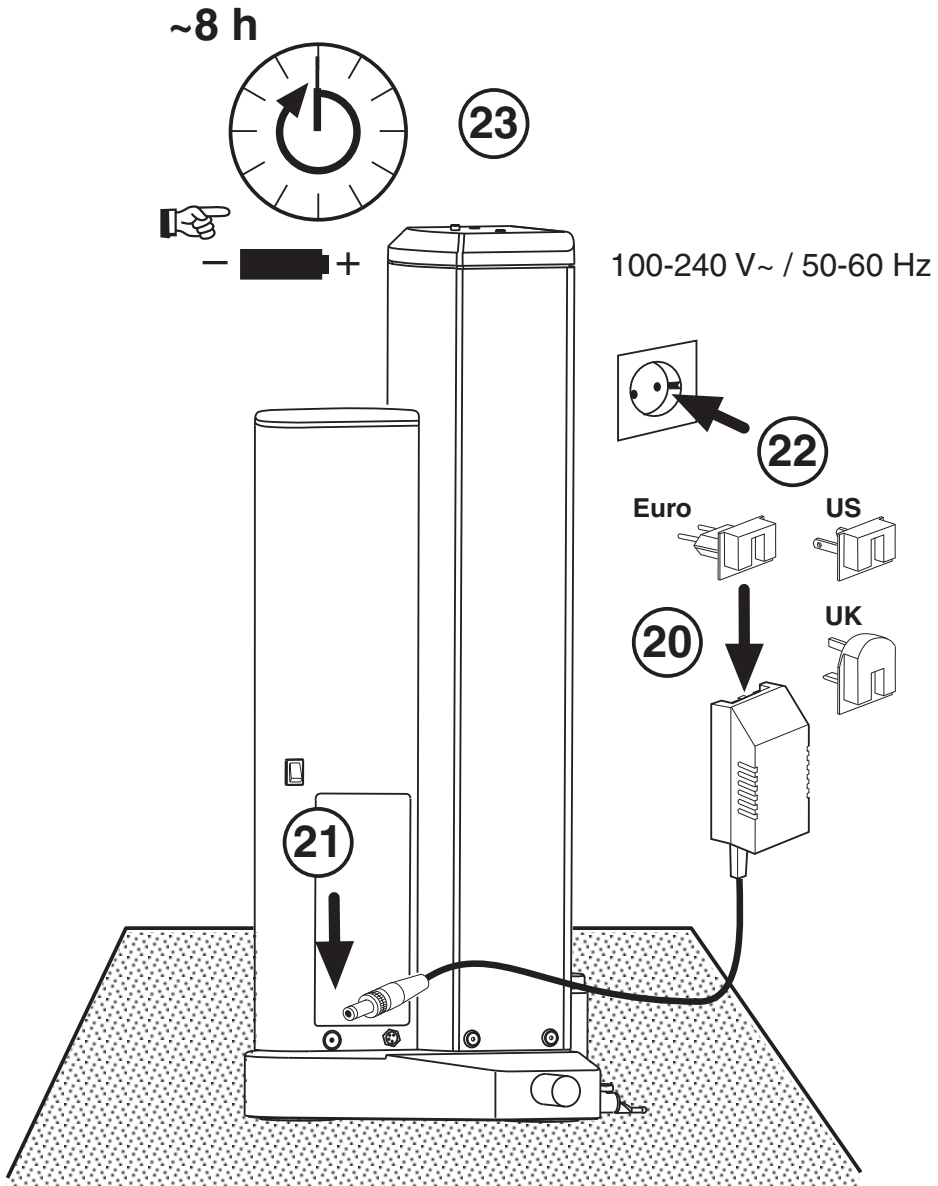

1.3 Description and explanation of the height measuring instrument

1.3.1 Height measuring instrument

- | | | | |
|---|-------------------------------------------|----|----------------------------------------|
| 1 | Transport protection screw | 10 | Hand grip |
| 2 | Mount for probing element carrier | 11 | Transport handle |
| 3 | Probing element carrier | 12 | Switch for activating the air bearings |
| 4 | Contact point | 13 | Socket for the battery charger |
| 5 | Limit (stop) plate | 14 | ON/OFF switch |
| 6 | LED indicator for battery power | 15 | Rechargeable battery compartment |
| 7 | Handle for manually positioning the slide | 16 | Interface for data output |
| 8 | Display | 17 | Battery charger |
| 9 | Keypad | | |

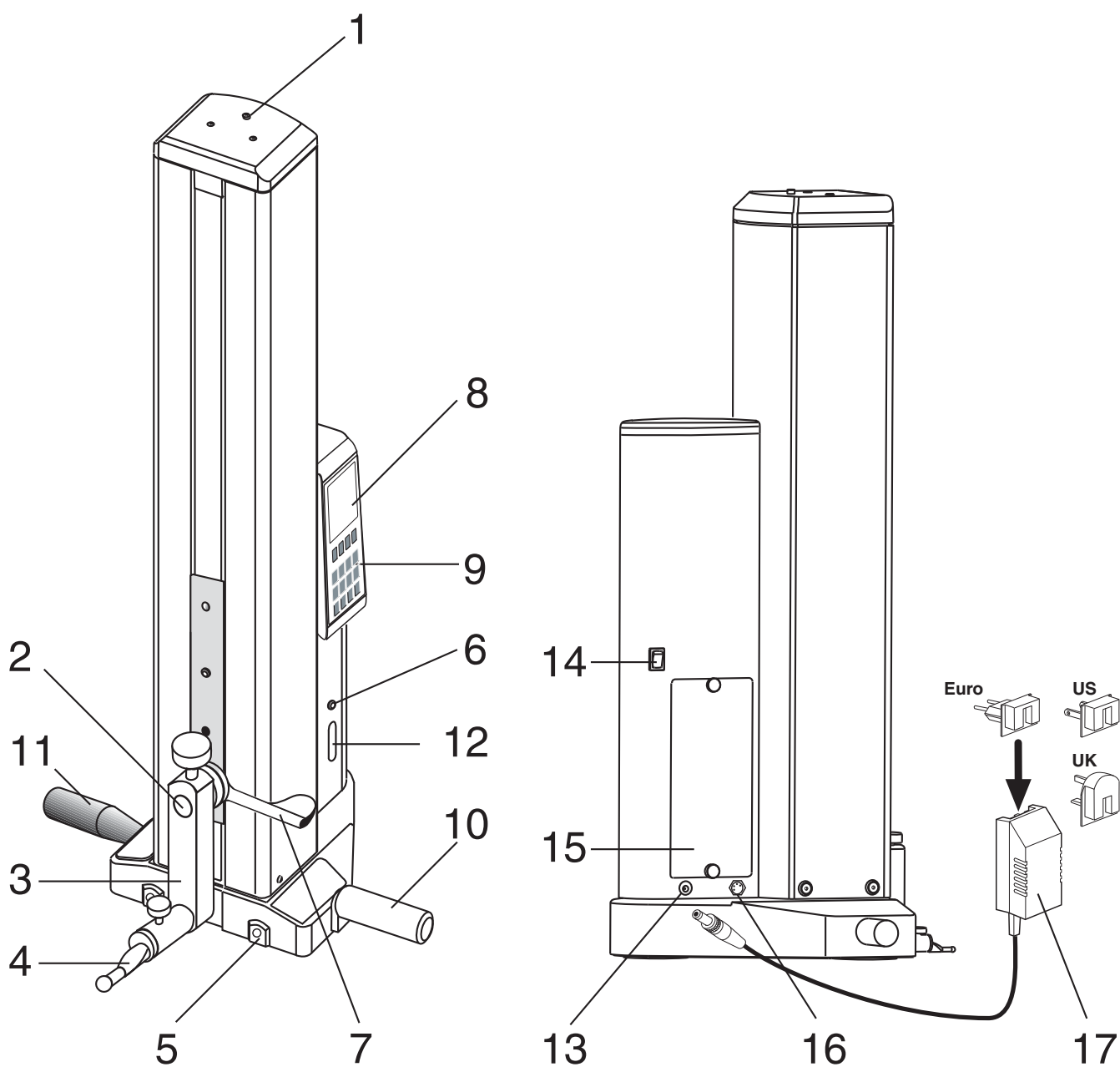

1.3.2 Keypad

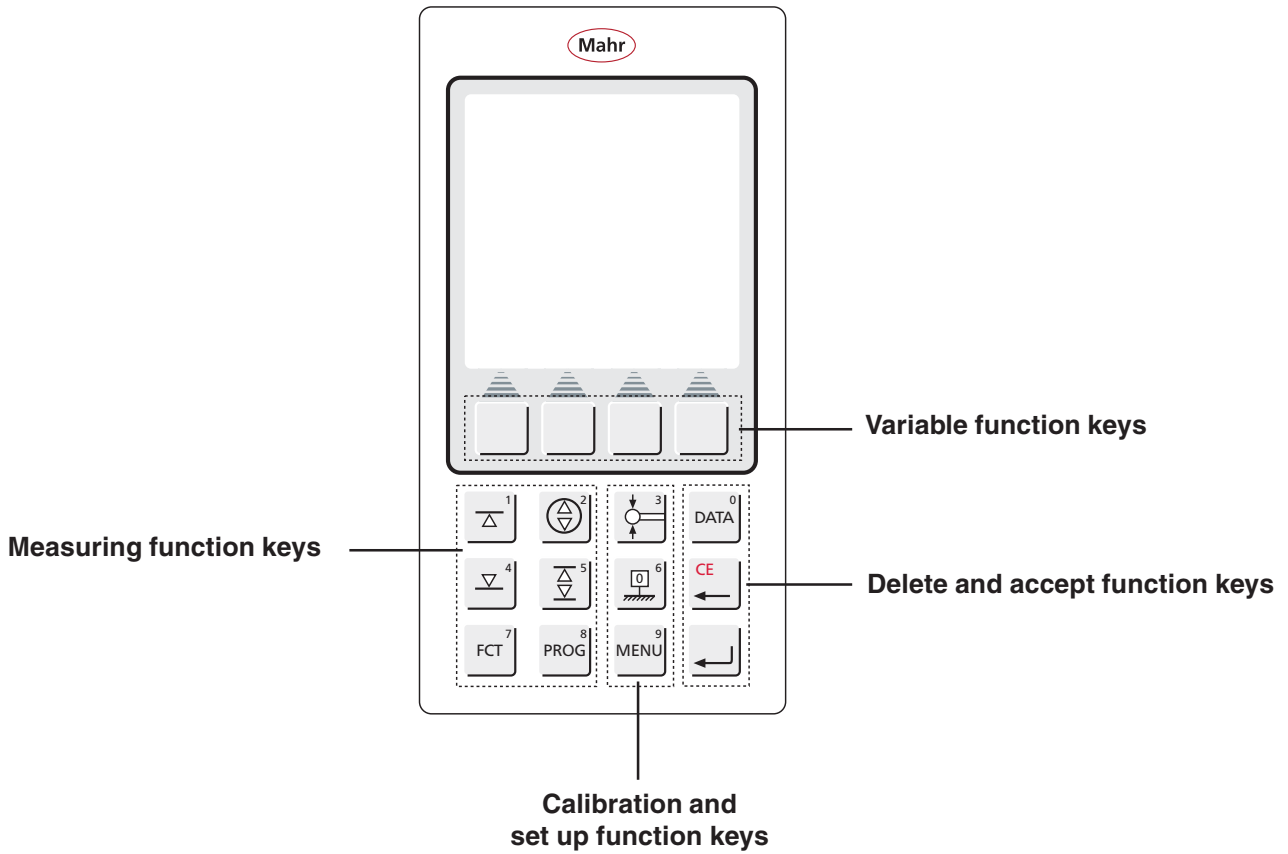



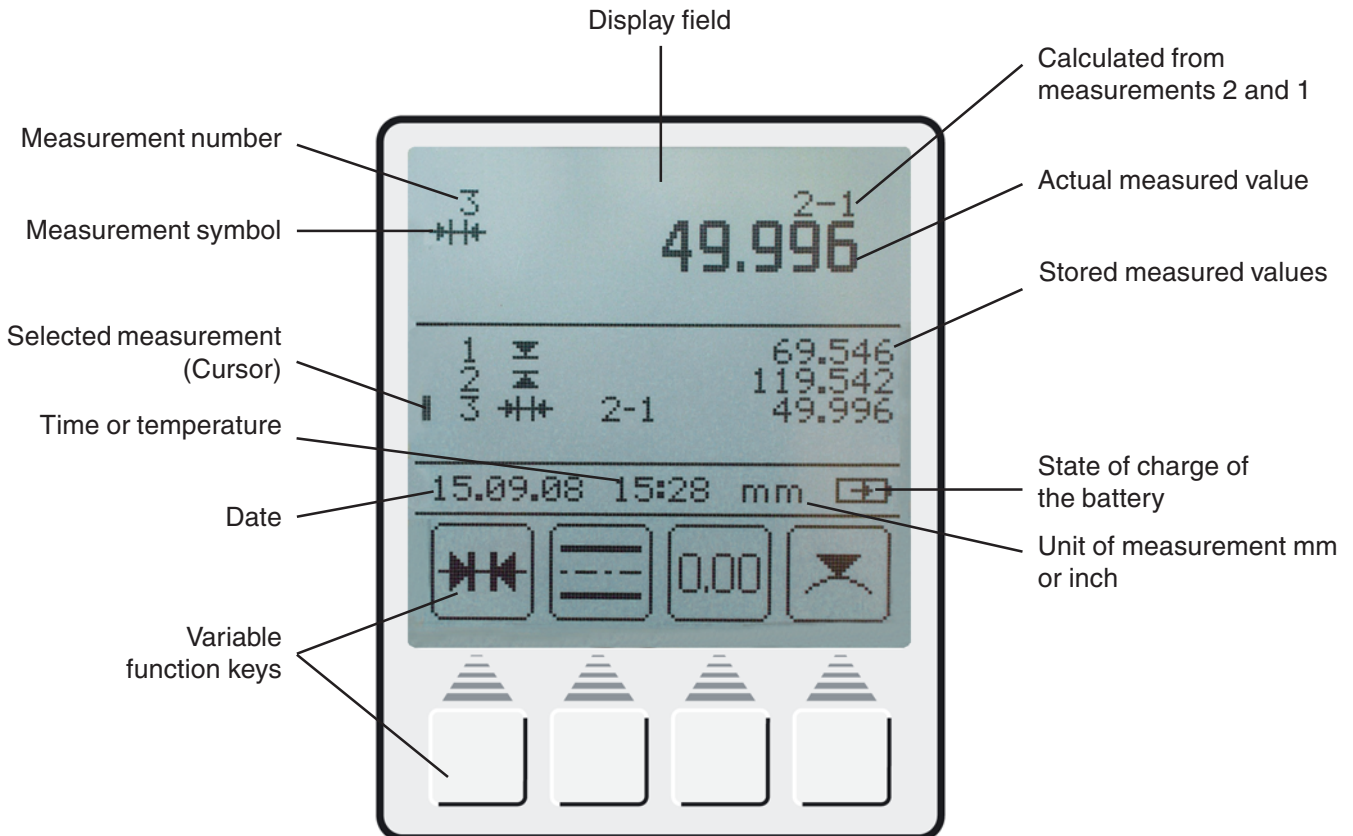







1.3.3 Display



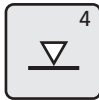











































1.3.4 Description of the symbols

















1.3.4.1 Keypad symbols

	Accept / Retrieve key		Delete / Return to last value / Cursor
	Select data for transmission		Calibrate a probe
	Menu settings		Setting the zero point on the base plate
	Contacting from below		Contacting from above
	Measuring a bore		Measuring a groove
	Further measuring functions		Measuring program functions

1.3.4.2 Function keys symbols

	Delete 1 measured value		Delete all measured values
	Delete the last measured value		Enter Preset (enter a numerical value)
	Calculate a distance		Calculate the symmetry
	Set the relative zero point		Absolute (change the zero point to the base plate)
	Pause		Continue
	Measuring a ledge		Contacting a ledge from above
	Measuring a shaft		Contacting a shaft from above

	Max-Min Function		Determining the center of a bore / displaying the position
	Contacting a bore from below		Contacting a bore from above
	Contacting a shaft from below		Contacting a shaft from above
	Cancel		Taper probe
	Calibrate probe using a groove		Calibrate the probe using a ledge
	Repeat / Continue		Stop / Accept
	Acoustic signal		Change resolution
	Contacting speed		Standstill time
	Contacting parameter		Time / Date
	Unit of measurement mm / inch		Show / Hide the list of results
	Factory settings		Add a new update
	Service / Customer service		Register
	Record header ON / OFF		Display measurement number ON / OFF
	Select diameter or coordinate		Return to last value / Enter
	Manual data transmission		Automatic data transmission

	Select a function		Send list of measured values		
	Cursor keys		YES NO Yes / No		
					
		Record program			Save program
		Start program			Pause program
	Display temperature		Active the temperature compensation		
	Temperature coefficient of the work piece		Select the list of measurements		
	Rolling list of measurements		Fixed list of measurements		

























Variable function keys





Depending upon measuring situation the symbols below the variable function keys will change. When pressed the keys will activate the function or go into the subdirectory (the next subordinated level).



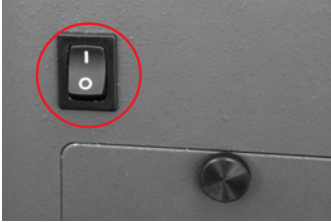

The different meanings are described in these operating instructions.

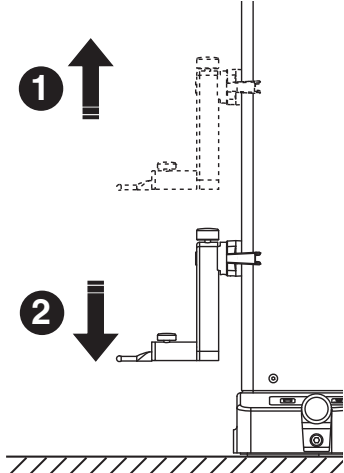

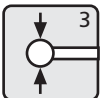

1.3.4.3 Symbols - display

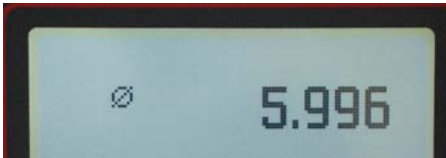
 Contacting from above	 Contacting from below	 Distance, groove
 Symmetry	 Distance	 Distance, ledge
 Display position	 Diameter	 Bore
 Bore from below	 Bore from above	 Coordinate
 Shaft from above	 Shaft from below	 Shaft
 max. value, contact from below	 max. value, contact from above	
 min. value, contact from above	 min. value, contact from below	
 Min Max	 Data transmission	 Temperature compensation is active

2. Commissioning / First steps

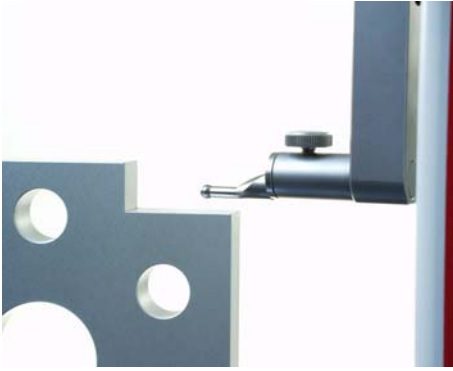
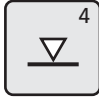
Description / Sequence	Symbols / Pictures
<p>2.1 Switching ON</p> <ul style="list-style-type: none"> – Switch the mains power supply to ON = (1). The switch which can be found at the rear of the height measuring instrument – The Boot up sequence will be start. – The measuring carriage of the height measuring instrument will move automatically to the reference point and set the zero point on the base plate. <p>Note: Once the zero point has been accepted, confirmation is given by 2 acoustic signals (beep).</p> <p>After the reference point has been confirmed, any zero point can be selected.</p>	   

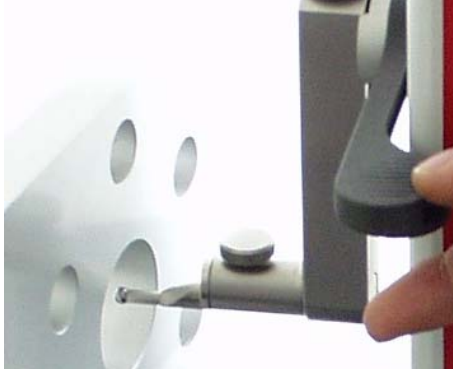
Description / Sequence	Symbols / Pictures
2.2 Calibrating a probe	
a) Press the „Calibrate a probe“ key	a) 
b) Press the function key „Calibrate in a groove“, the probe moves automatically to the center of the groove on the setting standard	b) 
c) Slide the setting standard, so that the probe is within the groove. The groove will be automatically measured for a second time.	c) 
d) The determined probe constant will be displayed.	d) 
<p>Note: The determined probe constant is always slightly smaller than the actual diameter of the probe (probe deflection- see Chapter 3.1)</p>	
2.3 Moving / positioning the height measuring instrument	
<p>By pressing the switch for the air bearing a ca. 9 µm high air cushion inflates underneath the height measuring instrument, enabling the operator to comfortably move and without jolting the height measuring instrument into the desired position upon the base plate. As soon as the switch for the air bearing is released, the air cushion will deflate and the height measuring instrument will once again stand firmly upon the base plate.</p>	
<p>Note: The pump for the air bearings should not be used continuously. This pump is only to be employed as a short-term pump to position / move the height measuring instrument.</p>	

Description / Sequence	Symbols / Pictures
<p>2.4 First measurement</p>	
<p>2.4.1 Contacting a plane from above</p>	
<ul style="list-style-type: none"> – Position the probe 	
<ul style="list-style-type: none"> – Press the „Contact from above“ key to start the measuring procedure 	
<p>In the display will appear the measured value</p>	
<p>2.4.2 Measuring a bore</p>	
<ul style="list-style-type: none"> – Position the probe in the bore (not in the center / eccentrically) 	
<ul style="list-style-type: none"> – Press the „Measure bore“ key to start the measuring procedure 	
<ul style="list-style-type: none"> – The probe will automatically travel upwards; the bore is contacted from below 	

Description / Sequence

- Move the work piece parallel to the limit plate (stop face) in order to determine the reversal point / maximum
- Acceptance of the reversal point will be confirmed by an acoustic signal (beep)
- The probe will automatically travel downwards; the bore is contacted from above.
- Move the work piece parallel to the limit plate (stop face) in order to determine the reversal point / minimum
- An acoustic signal will be emitted confirming acceptance of the reversal point; the results (center and diameter) will appear in the display.

Symbols / Pictures



2.5 Switching OFF

- The mains power supply switch can be found at the rear of the height measuring instrument
Switch the mains power supply to OFF = (0)



3. Operation and measuring

3.1 Standard calibration / calibrate a probe

Each calibration will automatically be conducted twice (x 2).

When calibrating the probe, the probe will automatically travel to the preset height of the gage block (92 mm).

Note:

The probe constant can be influenced by any of the following factors:

- Strain on the holder and the probe
- The reversal point of the measuring system
- The diameter of the probe

Attention:

The probe constant must be re-determined once a probe has been exchanged.

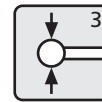

Possibilities:

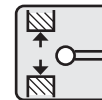

Groove
12.7 mm

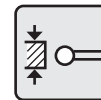

Ledge
6.35 mm



Taper
probe

Description / Sequence

Symbols / Pictures

3.1.1 Calibrating a probe using a groove

- Press the „Calibrate a probe“ key

- Press the function key „Calibrate using a groove“. The probe automatically travels the center of the groove of the setting standard

- Each calibration will automatically be conducted twice

- An acoustic signal (beep) will be emitted, confirming that the probe has made contact (the actual measured value will be shown in the display)

- Once calibration has been successful, the determined probe constant will be shown in the display.

Info:

The determined diameter is usually smaller than the real diameter as the probe deflection also has to be taken into account.

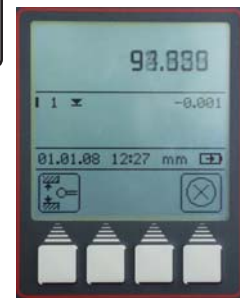
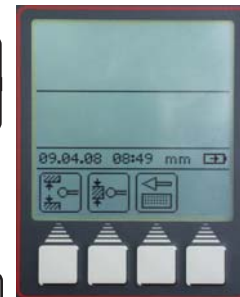
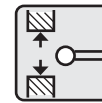
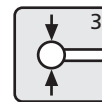

Description / Sequence

Symbols / Pictures

3.1.2 Calibrating a probe using a ledge

When calibrating a disc probe it is advisable to calibrate this disc probe with a ledge

- Press the „Calibrate a probe“ key
- Position the probe below the ledge
- Press the „Calibrate a probe using a ledge“ key
- The probe makes contact
- Probe travels automatically upwards
- Position the ledge below the probe
- The probe makes contact

Note: Procedure will be repeated automatically

- Probe travels automatically downwards
- Position the probe a second time below the ledge
- The probe makes contact
- Probe travels a second time above the ledge
- Position the ledge a second time below the probe
- The probe makes contact

Each time the probe makes contact an acoustic signal (beep) will be emitted

Once the calibration has been successful, the determined probe constant will appear in the display.

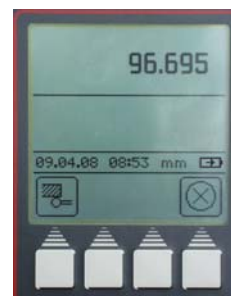
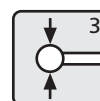

Description / Sequence

Symbols / Pictures

3.1.3 Calibrate with a taper probe

- Press the „Calibrate with a probe“ key
- Press the „Calibrate with a taper probe“ key
- Use the cursor keys and the numerals on the keypad to enter the diameter of the cone (e.g. 30 mm).
- Press the „Accept“ key
- Press the „Setting the zero point“ key and then the function key „Zero point“, to set a new zero point on the base plate
- The probe travels automatically to the base plate and sets a zero point

Note:

When measuring with a taper probe the radius will be also be included. Measuring procedure for taper probe, see Chapter 3.4.4.6

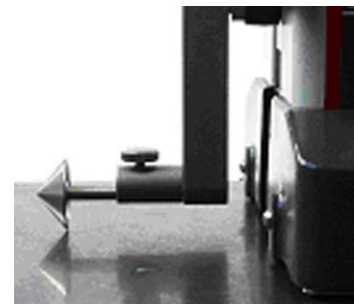
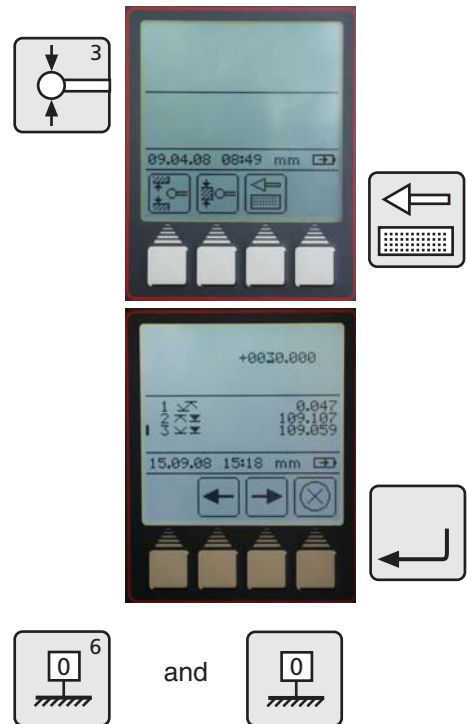

3.1.4 Deviations caused by calibration

Probes that have a large deflection (very long or very thin probes) can cause a deviation between the two measuring procedures.

The following function keys appear:

Conduct calibration once more, the average (mean) value will be calculated from the previous determined probe constant and the newly measured constant

Deviation is not accepted; the old value will be maintained. Probe constants with deviation will be shown in the status panel on the display

Abort measurement, all previous probe constants will be maintained.

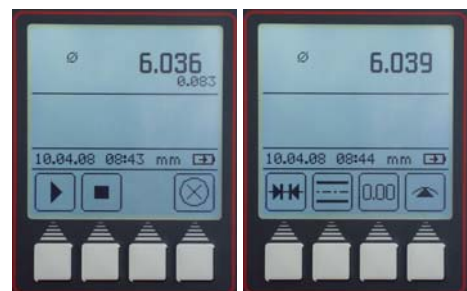

3.2 Zero points

- Basic-zero point, base plate
- Preset - zero offset

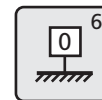

Description / Sequence

Symbols / Pictures

3.2.1 Set the zero point on the base plate

- Press the key „Setting the zero point“ on the keypad
- Press the „Zero point on the base plate“ function key
- The probe travels automatically to the base plate and the zero point is set

Standard display is 0.000

- After the reference point has been confirmed the „Zero point on the base plate“ it is possible to set zero point anywhere.

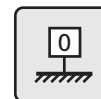
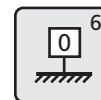

3.2.2 Entering a PRESET value

- A Preset can only be set upon an already measured value
- Press the key „Zero point“ on the keypad

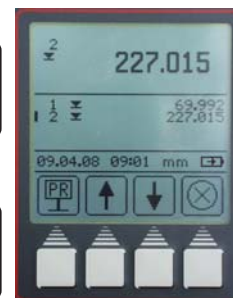
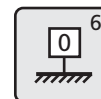









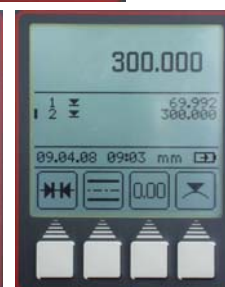
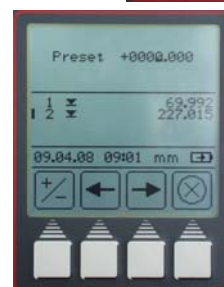







- Press the function key „Enter PRESET“
- Using the cursor keys, select a measured value, upon which the preset value should be applied, e.g. 2

- Once again press the function key „Enter PRESET“





- Enter the preset value using the cursor keys and the numerals on the keypad



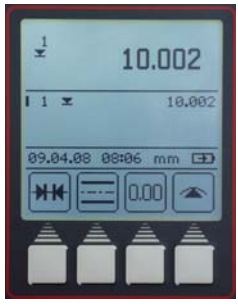

- The preset value of 300 mm applies to the dimension 227.015 (Measurement 2) as shown in this example.

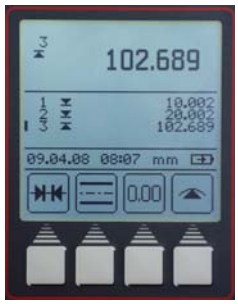

Description / Sequence	Symbols / Pictures
3.2.3 Expanding the measuring range	 and 
<ul style="list-style-type: none"> – Set the zero point on the base plate on the base plate – Use either a gage block or a predetermined work piece that is larger than 180 	
<ul style="list-style-type: none"> – Probe contacts the gage block or work piece e.g. dimension 226.467 	
<ul style="list-style-type: none"> – Loosen the clamping screw and turn the probe holder through 180° and then tighten the clamping screw back into position. 	
<ul style="list-style-type: none"> – Repeat the contact on either a gage block or a predetermined work piece 	      
<ul style="list-style-type: none"> – Press both the „Zero point“ and the „Preset“ key 	 
<ul style="list-style-type: none"> – Use the cursor keys to select a measured value and press „Preset“ 	
<ul style="list-style-type: none"> – With the cursor keys and the keypad enter the preset value (e.g. 226.467), to confirm press the „Accept“ key. 	
<ul style="list-style-type: none"> – See Measurement 2 Before 53.462 mm After 226.467 mm 	

3.3 Basic measuring functions

Description / Sequence	Symbols / Pictures
<p>3.3.1 Contacting from above</p> <ul style="list-style-type: none"> – Press the key „Contacting from above“ on the keypad <p>The measuring procedure will start</p> <p>The result will be shown as a large value and in the list of measuring characteristics as a symbol. Acceptance of the value will be confirmed by an acoustic signal.</p> <p>During measurement only the function key „Cancel“ can be used.</p>	<div data-bbox="1061 347 1157 436" style="display: inline-block; border: 1px solid black; padding: 5px; margin-right: 10px;">  </div> 
<p>3.3.2 Contacting from below</p> <ul style="list-style-type: none"> – Press the key „Contacting from below“ on the keypad <p>The measuring procedure will start</p> <p>The result will be shown as a large value and in the list of measuring characteristics as a symbol. Acceptance of the value will be confirmed by an acoustic signal.</p> <p>During measurement only the function key „Cancel“ can be used.</p>	<div data-bbox="1061 873 1157 963" style="display: inline-block; border: 1px solid black; padding: 5px; margin-right: 10px;">  </div> 
<p>3.3.3 Measuring a groove</p> <p>Position the probe in the upper section of a groove</p> <ul style="list-style-type: none"> – Press the „Measure a groove“ key on the keypad, the measurement procedure will start – The probe automatically travels upwards and then automatically downwards – During measurement only the function key „Cancel“ can be used – The results (width of the groove and the center of the groove) will be shown in the display. 	<div data-bbox="1061 1400 1157 1489" style="display: inline-block; border: 1px solid black; padding: 5px; margin-right: 10px;">  </div> 

Description / Sequence	Symbols / Pictures
<p>3.3.4 Measuring a bore</p> <ul style="list-style-type: none"> – Position the probe in the bore (not in the center / eccentricly) – Press the „Measure a bore“ on the keypad, the measurement procedure will start – The probe will automatically travel upwards and contact the bore from below – Move the work piece parallel to the limit plate (stop face) in order to determine the reversal point / maximum, acceptance of the reversal point will be confirmed by an acoustic signal (beep) – The probe will automatically travel downwards; the bore is contacted from above – Move the work piece parallel to the limit plate (stop face) in order to determine the reversal point / minimum, acceptance of the reversal point will be confirmed by an acoustic signal (beep) – The results (center and diameter) will appear in the display. 	  
<p>Tip When measuring large bore holes or when obstacles are present the measuring procedure can be interrupted by pressing the Pause key. Press the Continue key to proceed.</p>	 Continue  Pause
<p>Also see also to Chapter 2 - First measurement</p>	

3.4 Function keys

There are 4 variable function keys available. Three of this keys are fixed for calculations and / or setting the relative zero point.

The fourth key is variable and can be reserved with a measuring function from the FCT menu.



Symbols

- Calculating a distance
- Symmetry calculation
- Relative zero point
- Additional measuring functions



Description / Sequence

Symbols / Pictures

3.4.1 Calculating a distance

The difference between the last 2 stored measuring results will be calculated and shown in the display.



3.4.2 Calculating symmetry

The symmetry between the last 2 stored measuring results will be calculated and shown in the display.

The height of the line of symmetry related to the zero point will appear in the display.

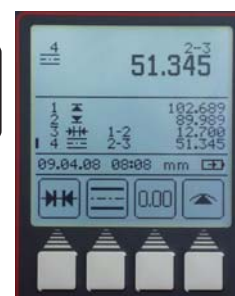

Description / Sequence

Symbols / Pictures

3.4.3 Relative / Absolute zero point

With this function a new zero point can be set relative to the base plate

- Press the function key „Set zero point“, the last measured characteristic / value will be shown in the display as Work piece-zero point 01. In this example, as dimension 227.017
- Once again contact the surface with dimension 227.017

All the measuring results are marked with 01 in the display that refer to the relative zero point

- By pressing the function key „ABS“ the zero point will change back to zero point on the base plate

The function key „0.00“ will reappear. All further measurements will be in relation to the base plate. The display symbol 00 will only appear once in the upper display field.

0,00



ABS



3.4.4 FCT-Function keys

- Press the „FCT“ key on the keypad

In this menu 8 more measuring functions can be selected.

When a function has been selected, this function will allocated to the fourth function key in the measuring menu. This function remains until a new function is selected. Therefore, those functions that are regularly used can be activated by pressing one key.

FCT⁷

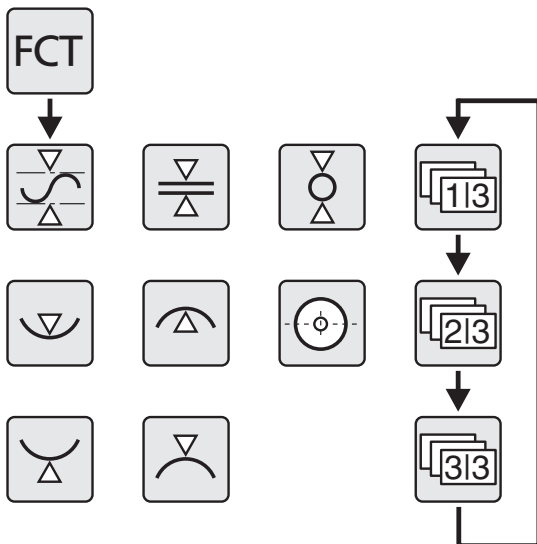

Description / Sequence

Symbols / Pictures

3.4.4.1 MAX/MIN-Function

- Press „FCT“ on the keypad and the function key „Max-Min“
- Select either contacting a plane from above or below, measurement will start
- By moving the work piece the change between Max, Min and the difference can be seen in the upper display field
- With the „Pause“ key the measurement will be stopped (put on hold), to continue measurement, press the „Continue“ key

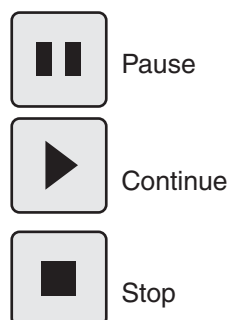
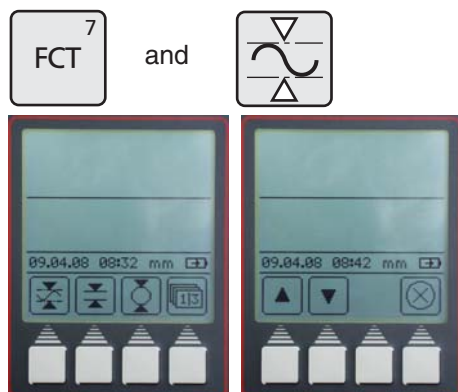

- Pressing the „Stop“ key will terminate the measurement, the difference between the maximum and minimum value will be shown in the display

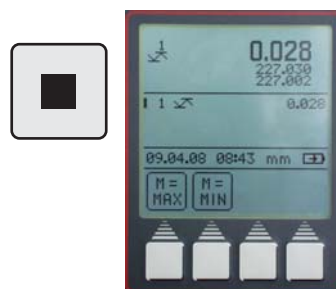







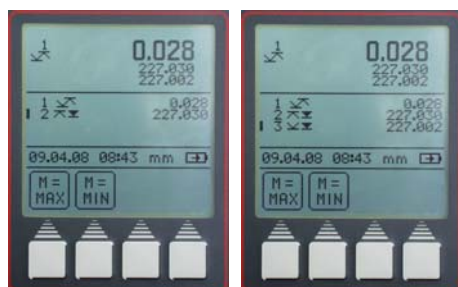



Further measured values can be viewed:

M = Max – maximum value
 M = Min – minimum value

- To exit the menu press the „CE“ key



Description / Sequence	Symbols / Pictures
3.4.4.2 Measuring a ledge	
<ul style="list-style-type: none"> Position the probe below the ledge 	 and 
<ul style="list-style-type: none"> Press the „FCT“ key on the keypad and then the function key „Measure a ledge“ 	
<ul style="list-style-type: none"> The probe automatically travels upwards and makes contact with the ledge 	
<ul style="list-style-type: none"> Position the probe above the ledge and press the „Contact a ledge from above“ key 	
<ul style="list-style-type: none"> The probe automatically travels downwards and makes contact with the ledge 	
<p>The width of the ledge and the position of the symmetry axis of the ledge will be shown in the display.</p>	
3.4.4.3 Measuring a shaft	
<ul style="list-style-type: none"> Position the probe below the shaft (not in the center / eccentrically) 	 and 
<ul style="list-style-type: none"> Press „FCT“ on the keypad and then the function key „Measure a shaft“ 	
<ul style="list-style-type: none"> The probe automatically travels upwards and makes contact with the shaft 	
<ul style="list-style-type: none"> Move the work piece parallel to the limit plate (stop face) in order to determine the reversal point / minimum, acoustic signal (beep) will confirm acceptance 	
<ul style="list-style-type: none"> Position the probe above the work piece (not in the center / eccentrically) 	
<ul style="list-style-type: none"> Press the „Contact a shaft from above“ key 	
<ul style="list-style-type: none"> The probe automatically travels downwards and makes contact with the shaft 	
<ul style="list-style-type: none"> Move the work piece parallel to the limit plate (stop face) in order to determine the reversal point (maximum), once the acoustic signal is emitted, the value has been accepted 	
<ul style="list-style-type: none"> The center point and the diameter will appear in the display. 	

Description / Sequence

Symbols / Pictures

3.4.4.4 Contacting a bore from below

- Position the probe eccentrically in the bore
- Press „FCT“ on the keypad and then the function key „Contact a bore from below“
- Move the work piece parallel to the limit plate (stop face) in order to determine the reversal point / minimum, the acoustic signal will confirm acceptance
- The minimum of bore will be shown in the display.

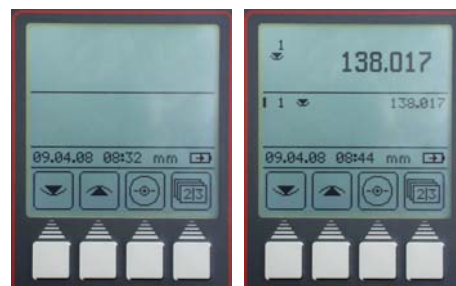

3.4.4.5 Contacting a bore from above

- Position the probe eccentrically in the bore
- Press „FCT“ on the keypad and then the function key „Contact a bore from above“
- Move the work piece parallel to the limit plate (stop face) in order to determine the reversal point / maximum, the acoustic signal will confirm acceptance
- The maximum of bore will be shown in the display.

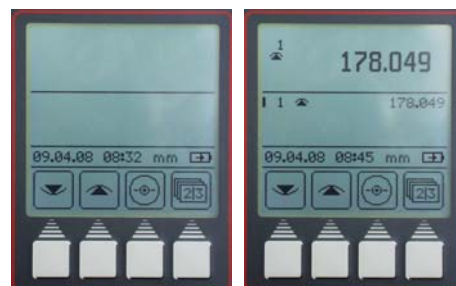
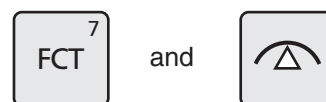

3.4.4.6 Center of a bore / display the position

Conduct the measuring procedure with a taper probe

Insert the taper probe into the center of the bore





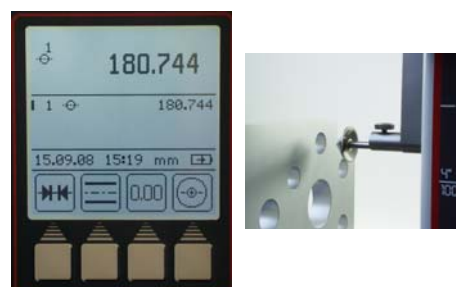
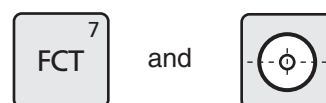

- Press the „FCT“ key and the function key „Bore center“

The center of the bore will appear in the display.



Note:



When exchanging a probe, the new probe must be calibrated.
See Chapter 3.1.3.













Description / Sequence	Symbols / Pictures
<p>3.4.4.7 Contacting a shaft from below</p> <ul style="list-style-type: none"> – Position the probe eccentrically – Press the „FCT“ key on the keypad and then the function key „Contact a shaft from below“ – Move the work piece parallel to the limit plate (stop face) in order to determine the reversal point / minimum, the acoustic signal will confirm acceptance – The minimum of the shaft will be shown in the display. 	<div style="display: flex; align-items: center; justify-content: center; gap: 20px;"> <div style="border: 1px solid black; padding: 5px; text-align: center;">FCT⁷</div> and <div style="border: 1px solid black; padding: 5px; text-align: center;">  </div> </div> <div style="display: flex; justify-content: space-around;">   </div>
<p>3.4.4.8 Contacting a shaft from above</p> <ul style="list-style-type: none"> – Position the probe eccentrically – Press the „FCT“ key on the keypad and then the function key „Contact a shaft from above“ – Move the work piece parallel to the limit plate (stop face) in order to determine the reversal point / maximum, the acoustic signal will confirm acceptance – The maximum of the shaft will be shown in the display. 	<div style="display: flex; align-items: center; justify-content: center; gap: 20px;"> <div style="border: 1px solid black; padding: 5px; text-align: center;">FCT⁷</div> and <div style="border: 1px solid black; padding: 5px; text-align: center;">  </div> </div> <div style="display: flex; justify-content: space-around;">   </div>

4 Delete, save and print measured values

4.1 Delete

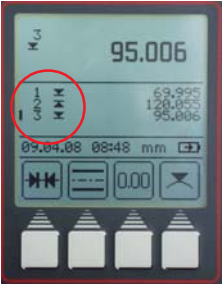
Symbols

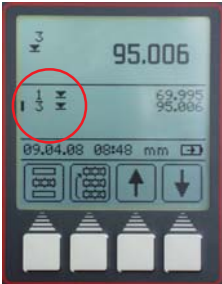
- Delete all measurements 
- Delete only the last measurement 
- Delete an individual measurement 

Description / Sequence	Symbols / Pictures
<p>4.1.1 Delete all measurements</p> <ul style="list-style-type: none"> - Press the „CE“ key - Press the „Delete all measurements“ key. The list of measurements will be completely deleted. - Press the „Delete the last measurement“ key. Only the last measurement will be deleted (only in the measuring mode - rolling list of measured values). 	   
<p>4.1.2 Delete an individual measurement</p> <ul style="list-style-type: none"> - Position the cursor upon the individual measurement with the arrow keys (up - down) - Press Taste „Delete 1 measured value“ key. Only the selected measurement will be deleted (only in the measuring mode - fixed list of measured values). - Press the „Accept“ key to exit the delete menu 	        
<p>Note: To change measured values list (rolling or fixed) see Chapter 5.13.</p>	

Description / Sequence

4.1.3 Delete an entry

In some input windows for example; in the Preset window it is possible to delete incorrect entries

- Position the cursor with the arrow keys (left and right) upon the digit / entry which is to be deleted. Press the „CE“ key to delete the digit.

4.1.4 Return

- Press the „CE“ key to return to next above menu.

4.2 Print measured values

Description / Sequence

4.2.1 Print with an MSP2 printer

On the printer select the interface to be used, either Opto Duplex or the ASCII printer mode.

Note:
Settings see Chapter 5.1 - Data transmission

Connect the RS232 connection cable to the INPUT on the printer (without a Simplex / Duplex adapter)

2000r Data cable Order no. 4346020

4.3 Sending measured values

- By pressing the „DATA“ key, measured values can either be sent manually i.e. singularly

When data is being transmitted the following symbol will appear in the display of the height measuring instrument

Settings see Chapter 5.1 - Data transmission and Chapter Software.

Symbols / Pictures



Symbols / Pictures

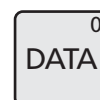
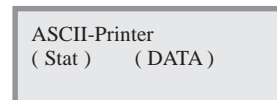
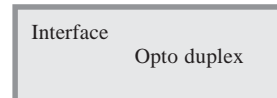



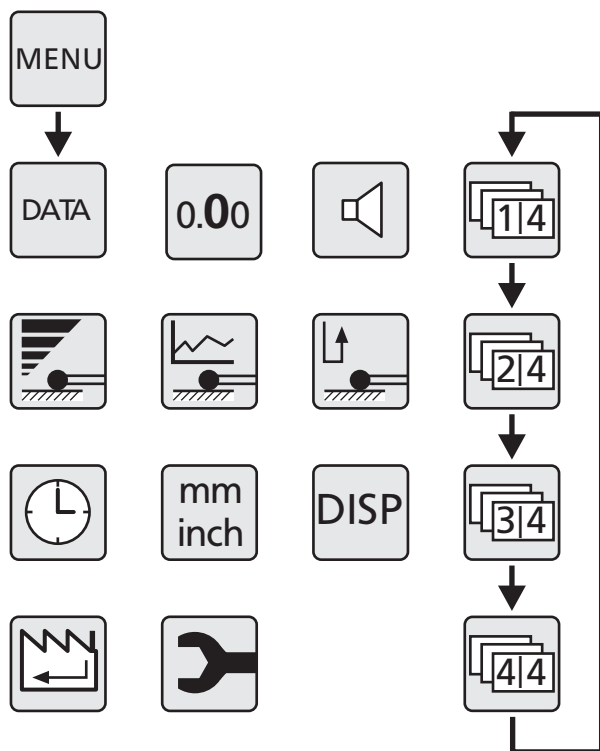



5 Menu - Basic settings







5.1 Data transmission

5.1.1 Basic settings / Symbols

Symbols

- Settings for data transmission  
- Sending a series of measuring data 
- Setting the format of measuring data output 
- Record header 
- Diameter and coordinate 
- Only diameter 

- Only coordinate 
- Manual data transmission 
- Automatic data transmission 
- Display the measurement number 

5.1.2 Interfaces

Interface: MarConnect RS232C duplex

Suitable data connection cables:

- Opto RS232C (2m), SUB-D socket 9 pin Order no. 4346020
- 2000 usb (2m), incl. MarCom Standard Order no. 4346023

Date transmission with the data connection cable 4346020 is not possible when being operated with Simplex!

Transfer parameter

Transfer speed: 4800 Baud, 1 start bit, 7 ASCII-bits, even parity, 2 stop bits

Connection

Functions on the data cable			Functions on the PC	
9 pin D-Sub socket				
TxD	data output	2	2	RxD
RxD	data input	3	3	TxD
V+	power supply	4	4	DTR
V-	power supply	7	7	RTS

Duplex operation (without adapter 4346394)

PC-side

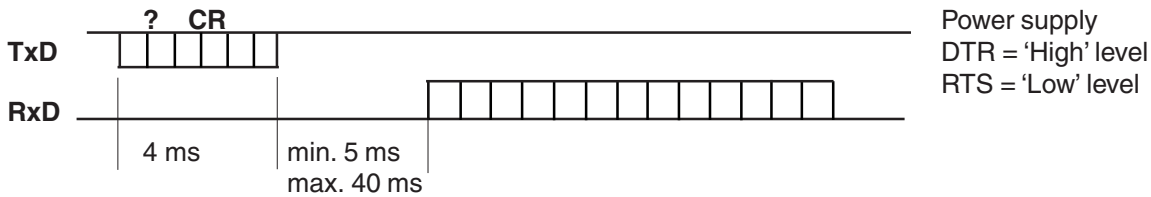

- In this operating mode it is only possible to call up the measuring value in the format $\pm XXX.XX(X)_{mm}<CR>$ resp. $\pm XX.XXXX(X)_{inch}<CR>$.
- If the time between individual characters is longer than 30 ms (approx. 15 characters), then this will result in subsequent characters being interpreted as new instructions.
- After receipt of the instruction RS232-receipt is being locked until the instruction is being executed. Each reply string is terminated by CR.

- If, with a measurement series the measurement number and the record header are sent, then this will be sent in the following format:
 DIGIMAR_816CL_1.3A
 21.01.09__12:54
 THESE
 4 ROWS
 CAN BE
 FREELY EDITED
 _1___+1.234_mm or _1___+1.23456_inch
 21___+12.345_mm or _1___+12.34567_inch

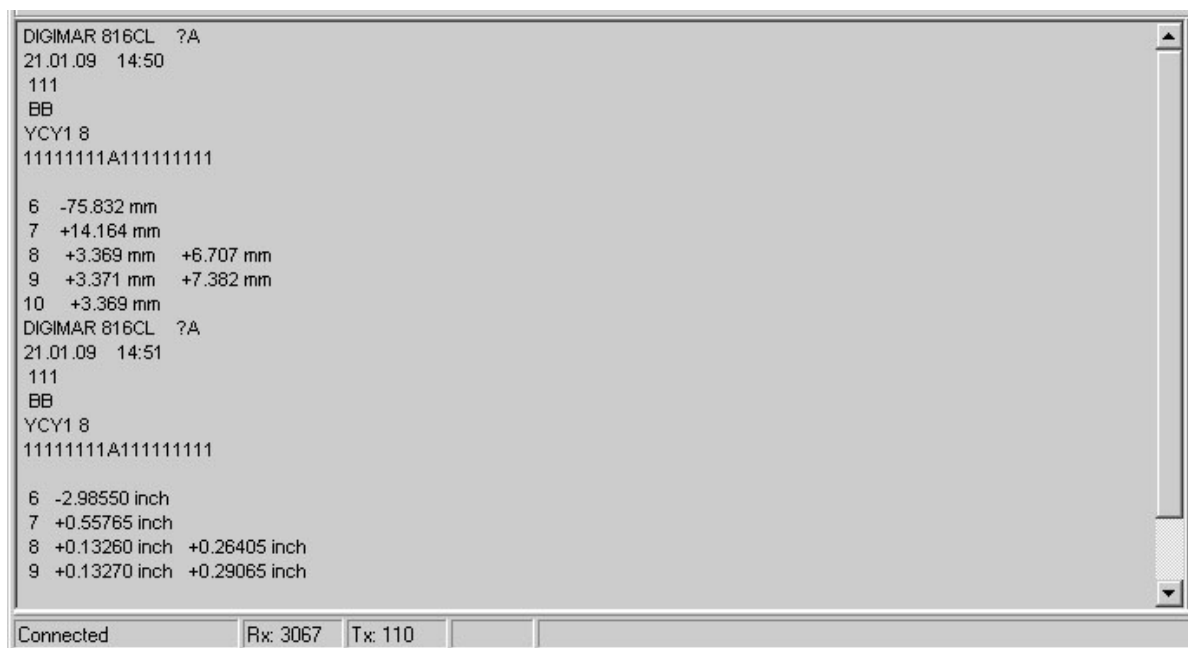

Description / Sequence

Symbols / Pictures

5.1.3 Sending a series of measured data

- In Menu, press the „DATA“ key
- Press the function key „Send a series of measured values“

All measured data that are in the memory will be transferred simultaneously according to the how the measured data output is set to either a PC or a printer.

See Chapter 7.1 Data transmission with MarCom and
 See Chapter 5.1.2 Interfaces

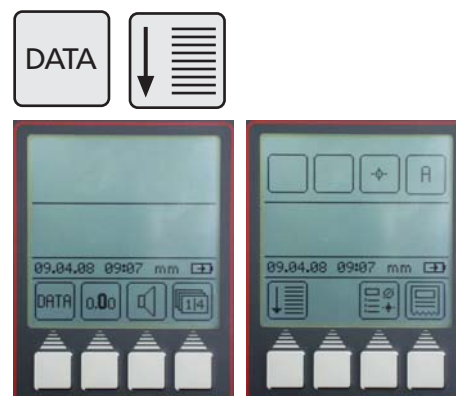

Description / Sequence

Symbols / Pictures

5.1.4 Select measured data

- Press the function key „Select measured data“

Actual settings will be shown in the display

- Transmit the record header: ON or OFF
- Transmit the measurement numbers: ON or OFF
- Switch between:
 - Diameter
 - Coordinate
 - Diameter and coordinate
- Switch between automatic / manual data transmission
 A means that after measurement, the measured value will automatically be transmitted.
 M means that the DATA key has to be pressed to send a value.
- To confirm selection, press the „Accept“ key



Record header



ON

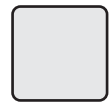

OFF

Measurement number



ON



OFF

Diameter/ Coordinate



Manual / Auto. Data transmission



5.1.5 Create a record header

- To create a header press the „Record header“ key

The record header consists of 2 blocks:

1. Two predetermined and permanent rows, these are:

DIGIMAR 816CL V 1.3A
09.10.08 09:07

This is only visual when printed

2. Four freely available rows, which are made up of 18 characters

- Select the row with the „Cursor“ key and confirm with the „Accept“ key



Description / Sequence

Symbols / Pictures

- To scroll, use the „Cursor“ keys
- To switch between upper and lower case letters as well as special characters by pressing the „Accept“ key

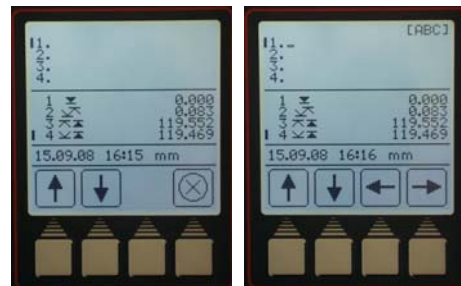

Upper case letters, press [ABC]
 Lower case letters, press [abc]
 Special characters, press [# * +]

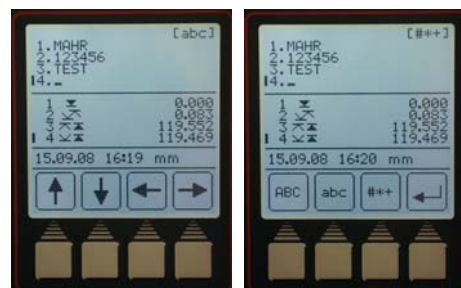

- To return to the input menu press the „Accept“ key
- To delete a character or a complete row, press the „CE“ key
- Press the „Accept“ key to confirm
- To exit the text input, press the „Cancel“ key



5.2 Resolution

The resolution in which the measured results will be displayed.
Standard setting: Resolution 0.001 mm



- Press the function key „Resolution“
- Select the resolution with the arrow keys

Note:

To change to the unit of measurement from mm to inch, see Chapter 5.8.

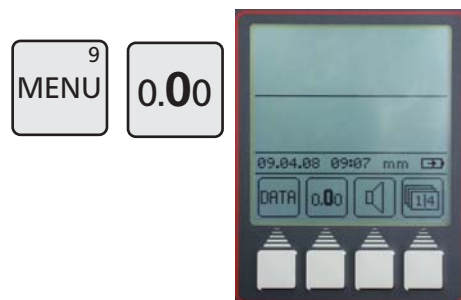
- Confirm by pressing the „Accept“ key

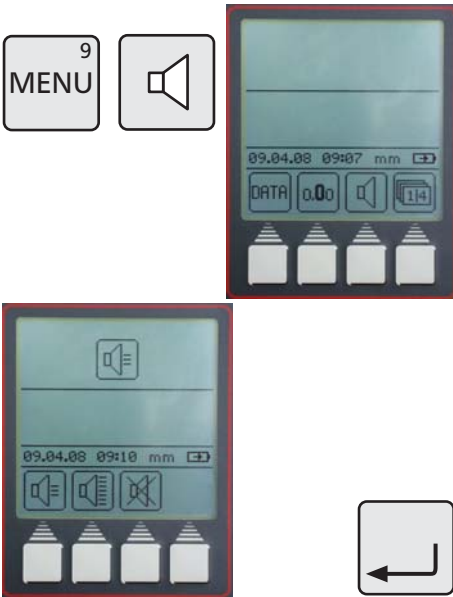

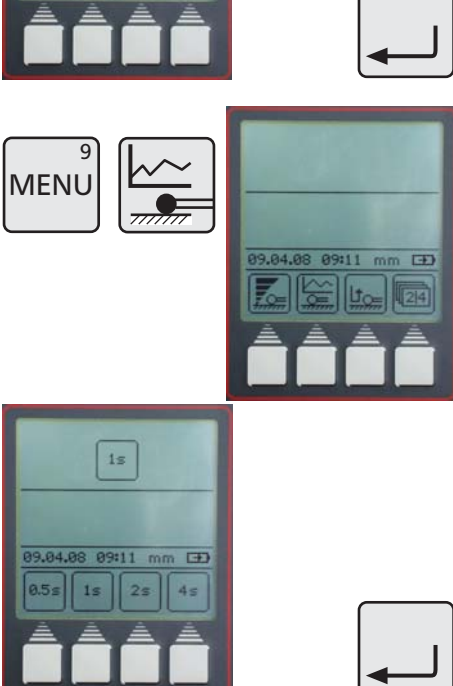
Description / Sequence	Symbols / Pictures
<p>5.3 Acoustic signal tone</p> <p>The signal tone can be quiet / loud / off Standard setting: Loud</p> <ul style="list-style-type: none"> - Press the function key „Acoustic signal“ - Select the acoustic signal <ul style="list-style-type: none"> - Tone quiet - Tone loud - Tone off - Confirm by pressing the „Accept“ key 	
<p>5.4 Contacting speed</p> <p>Standard setting: Speed 8 mm/s</p> <ul style="list-style-type: none"> - Press the function key „Contacting speed“ - Select the contacting speed mm / second - Confirm by pressing the „Accept“ key 	
<p>5.5 Standstill-time</p> <p>When making contact with the work piece, the probe bounces for a short time and the measuring value oscillates accordingly. The measuring value can only be accepted when it is stable. Thus a suitable time constant - the die-down time - needs to be selected. The standard die-down time is 1 second. The operator can decide whether another die-down time (0.5; 1; 2; 4 s) is required.</p> <p>Standard setting: Standstill-time 1 s</p> <ul style="list-style-type: none"> - Press the function key „Standstill-time“ - Select the standstill-time - Confirm by pressing the „Accept“ key 	

Description / Sequence

Symbols / Pictures

5.6 Contact parameter (probe lift)

Standard setting: Lifting is activated

- Press the function key „Contact parameter“
- Lift probe (2 mm) after contact is made
- Contacting without a probe lift (recommended when measuring small diameters or distances)
- Confirm by pressing the „Accept“ key

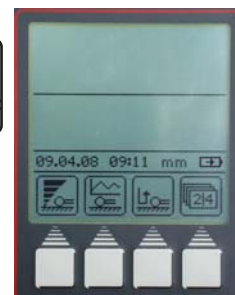

5.7 Time / Date

In the display, the actual time and date are shown; these can be changed by using the „Cursor“ keys

- Press the function key „Time / Date“
- Use the arrows keys on the keypad to move the cursor in order to make the appropriate changes.
- To enter changes, use the numbers on the function keys

DD = Day MM = Month YY = Year

hh = Hours mm = Minutes

- Confirm by pressing the „Accept“ key



5.8 Switching the unit of measurement mm / inch

Select a unit of measurement, either mm or inch.

Standard setting: Unit of measurement mm

- Press the function key „mm / inch“
- Select the unit of measurement
- Confirm by pressing the „Accept“ key

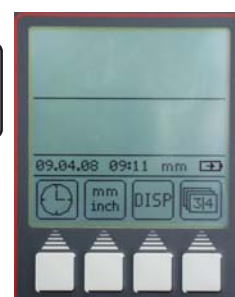

Description / Sequence

Symbols / Pictures

5.9 Display

Standard setting: Measurement list activated

- Press the function key „Display“
- The measurement list can be shown or hidden
- Confirm by pressing the „Accept“ key

Note:

The measured values are not lost!

5.10 Factory settings

- Press the function key „Factory settings“

- Accept - Yes or No

The height measuring instrument will return to the default / factory settings.

Basic (default) settings

Unit of measurement:	mm
Resolution:	0.001 / 0.00005"
Acoustic signal tone:	Loud
Contacting speed:	8 mm/s
Standstill-time:	1 s
4 Function keys:	Max-Min function
Contact parameter:	Probe lift
Preset value:	0 mm
Saved probe constants:	0
List of measuring results:	Visual
List of measuring results:	Empty
List of measurements:	Rolling
Data transmission settings:	without record header without measurement numbers Measured value: coordinate Auto data transmission Record header is empty

5.11 Service / Customer service

This menu is exclusively reserved for Mahr-Service personnel.



Description / Sequence

Symbols / Pictures

5.12 Select a list of measurements

Standard setting: Rolling list

- Press the function key „List of measurements“
- Select the symbol measurement list

Rolling list

- 99 measurements are stored internally.
Each new measurement is placed at the end of the list, simultaneously the first measured value in the list will be deleted.

Fixed list

- 99 characteristics are stored internally.
Each new characteristic will appear in the display but will not be stored in the list of measurements.
- In the fixed list mode individual measurements can be deleted from the list.

Note:

Changing between the fixed and the rolling list is only possible, when the list is empty!
Gaps / deleted measurements will not be filled.

5.13 Software update

- With the menu key, select the „Factory settings“
- Select the symbol „Software update“

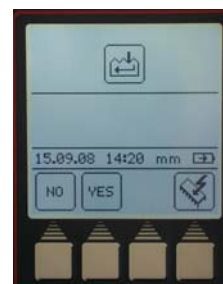
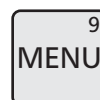

Description / Sequence

- Connect either the data connection cable Opto RS232 (Order no. 4346020, without an adapter) or USB cable (Order no. 4346023) to a PC and the height measuring instrument.

- Start the VariFlashEasy program

- Set up configuration (when using a COM interface, generally select COM1)

Note:

When using a USB cable a virtual COM interface can be generated under Control Panel - System - Hardware - Device Manager - Ports - Serial-Port. The COM Port number, for example COM2 can be assigned in the Serial Interface.

- Select the actual program file

- Press the push button „Software update“

- The progress of the download will be indicated

- The transmission software update is a success.

Symbols / Pictures





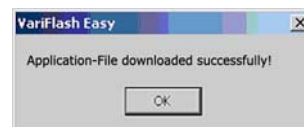
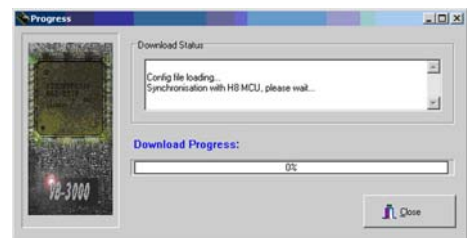









VariFlashEasy Update-Software 816 CL.Ink

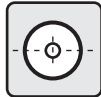
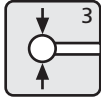
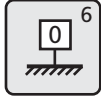

6. Measuring program



The height measuring instrument can save a measuring procedure and thus create a measuring a program from the saved data.

Description / Sequence	Symbols / Pictures
<p>6.1 Create a measuring program</p>	
<p>It is possible to save 1 program.</p>	
<p>All functions up to:</p>	<div style="display: flex; flex-direction: column; gap: 10px;"> <div style="display: flex; align-items: center;">  <div style="margin-left: 10px;">Record program</div> </div> <div style="display: flex; align-items: center;">  <div style="margin-left: 10px;">Save program</div> </div> <div style="display: flex; align-items: center;">  <div style="margin-left: 10px;">Start program</div> </div> <div style="display: flex; align-items: center;">  <div style="margin-left: 10px;">Pause program</div> </div> </div>
<div style="display: flex; flex-direction: column; gap: 20px;"> <div style="display: flex; align-items: center;"> <div style="margin-right: 20px;">Min/Max</div>  </div> <div style="display: flex; align-items: center;"> <div style="margin-right: 20px;">Center of a bore / display position</div>  </div> <div style="display: flex; align-items: center;"> <div style="margin-right: 20px;">Calibrate a probe</div>  </div> <div style="display: flex; align-items: center;"> <div style="margin-right: 20px;">Set a zero point</div>  </div> </div>	
<p>can be used.</p>	
<p>Record and save a measuring program</p>	
<ul style="list-style-type: none"> - Press the „PROG“ key - Press the „Record program“ key - if necessary delete stored measured values 	<div style="display: flex; flex-direction: column; align-items: center; gap: 10px;">    </div> <div style="margin-top: 20px;">  </div>
<ul style="list-style-type: none"> - Measure the work piece <p>With the „Pause“ key it is possible to insert a pause between 2 measurements, the pause lasts for 4 seconds.</p>	<div style="display: flex; flex-direction: column; align-items: center; gap: 10px;">   </div> <div style="margin-top: 20px;">  </div>

Description / Sequence

- Press the „PROG“ key
- To store the measuring program, press the „Save program “ key.

6.2 Start a measuring program

When starting a measuring program a reference for the positioning of the zero point will be set on the base plate. This can be anywhere.

Before starting the program, position the work piece

- Press the „Start program“ key
- The height measuring instrument will automatically travel to the stored measuring steps
- The program can at anytime be aborted by pressing „Cancel“ key or can be halted or stopped with the „Pause“ key.

Note:

A distance or symmetry calculation is only possible, when the last 2 values in the measured value list are position values (not a distance value and not a Max or Min value).

Exception: In the measuring program Pause and DATA for the calculation are ignored, i.e. it is not included in the list, for example:

- 1 Bore 1
- 2 Pause
- 3 Bore 2

the symmetry of both bores (Bore 1 and Bore 2) are calculated.

- Should a measurement be deleted during the programming
- Press „CE“ and either the last or all measured values will be deleted.

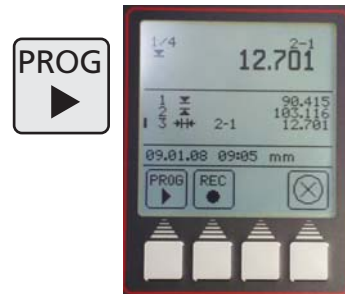
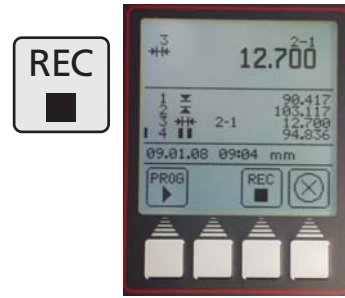

Symbols / Pictures

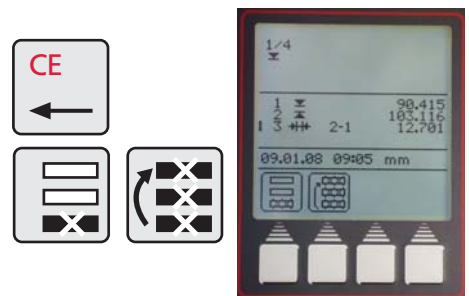

Measurement 1 from 4 = 1/4

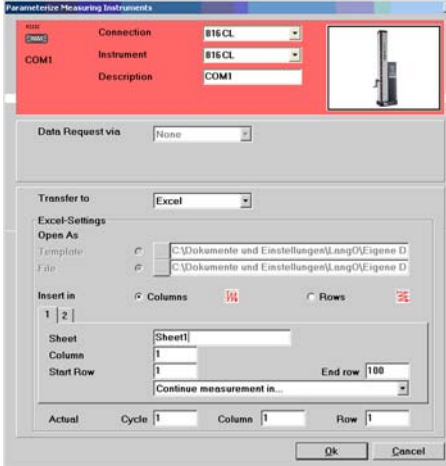

7. Additional functions

Description / Sequence	Symbols / Pictures
<p>7.1 Data transmission with MarCom</p> <p>To transmit data we offer 2 versions of data transmission software.</p> <p>MarCom-Standard – Data transmission for</p> <ul style="list-style-type: none"> – a measuring instrument with a USB interface – a measuring instrument with a RS232 interface – a foot switch with a USB interface <p>MarCom-Professional – Data transmission for</p> <ul style="list-style-type: none"> – more than 100 measuring instruments / foot switches that have a USB interface – 2 measuring instruments with a RS232 interface <p>Only our USB cable can be used.</p> <p>The measured values can be directly sent to</p> <ul style="list-style-type: none"> – Excel – a Text file – or via a keyboard (Enter, Tab,...) to any file <p>System requirements:</p> <p>Windows 2000, XP, Vista USB port 1.1 or higher Min. 10 MB memory CD/DVD drive for installation Recommended: MS Excel from version 97</p> <p>On the height measuring instrument the type of data transmission can be selected.</p> <ul style="list-style-type: none"> – Auto or Manual <p>Also see Chapter 5.1.2 Interfaces</p>	   <div style="display: flex; flex-direction: column; align-items: center; gap: 10px;"> <div data-bbox="1062 1397 1161 1496" style="border: 1px solid gray; padding: 5px; text-align: center;">9 MENU</div> <div data-bbox="1062 1514 1161 1612" style="border: 1px solid gray; padding: 5px; text-align: center;">0 DATA</div> <div data-bbox="1062 1630 1161 1729" style="border: 1px solid gray; padding: 5px; text-align: center;">  </div> <div data-bbox="1062 1747 1161 1845" style="border: 1px solid gray; padding: 5px; text-align: center; font-size: 24px;">A</div> <div data-bbox="1062 1863 1161 1962" style="border: 1px solid gray; padding: 5px; text-align: center; font-size: 24px;">M</div> </div>

Description / Sequence

Symbols / Pictures

7.2 Temperature compensation

The **Coefficient of expansion** or **coefficient of thermal expansion** is the dimensional response of a work piece / material to a change of temperature (expansion or contraction).

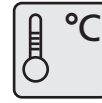

Display temperature



Active the temperature compensation



Temperature coefficient of a work piece

7.2.1 Display the temperature

- Press the „Menu“ key and then the „Time“ function key



- Press the function key „Display temperature“ – the temperature will replace the time in the display.



Note:

The time and the temperature cannot be displayed simultaneously.

7.2.2 Active the temperature compensation

- Press the „Menu“ key and then the „Factory settings“ function key



Description / Sequence

Symbols / Pictures

- Press the function key „Temperature compensation“

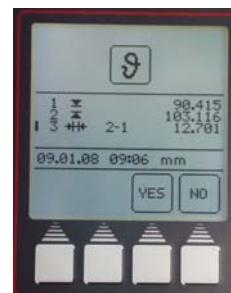

- With the „YES“ or „NO“ keys the temperature compensation can be switched ON or OFF



- Enter the coefficient of expansion, for example:

Steel 11,500 $\mu\text{m}/\text{m}/^\circ\text{C}$

Aluminum 23,8 $\mu\text{m}/\text{m}/^\circ\text{C}$



- To confirm, press the „Accept“ key



If measurement is being conducted in inch, the display will switch from $^\circ\text{C}$ to $^\circ\text{F}$ (Fahrenheit).

The coefficient of expansion can be entered in $\mu\text{inch}/\text{inch}/^\circ\text{F}$.

Note:

When the temperature compensation is switched on, it does not compensate if the ambient temperature lies within the calibration temperature $\pm 1^\circ\text{C}$ or during usage or when the temperature drops below 10°C or above 40°C .

If the temperature sensor is missing or when switching on the height measuring instrument the temperature is below 10°C or above 40°C , the operator must switch off the temperature compensation.

When the temperature compensation is active a T in a square is displayed in on the top right corner of the display.



If the temperature compensation is switched on, but at present not active only an empty square is indicated.

8. Self help, maintenance and care

8.1 Maintenance and care

Make sure that the base plate is always clean. The base plate should be freed daily of any dust, oil or cooling agents. Dirt on the air bearings has a negative influence on both the measurement and the accuracy.



8.1.1 Cleaning the height measuring instrument

The height measuring instrument can be cleaned with a slightly moistened cloth. Do not use detergents, which are harmful to plastics! To clean the air bearings use a little methylated spirits (alcohol).

8.1.2 Charging the batteries

To charge the batteries the battery charger must be plugged in the socket for the charger. The charge status of the batteries will be indicated by the  battery symbol in the display.

Above the switch for the air bearings is an LED; when this LED is red, the battery charger (power pack) is connected.

When the batteries are completely discharged, a minimum of 5 hours are required until the batteries are once again fully charged. The battery charger can be permanently connected to the height measuring instrument without any risk as the charger has a intelligent overload protection which prevents overcharging. The batteries are charged when the measuring height instrument is switched ON.

Note:

Over the course of time, batteries, which are not, used will discharge. Discharged batteries lose their capacity and may cease to function. To avoid this, batteries should be fully charged every 3 months.

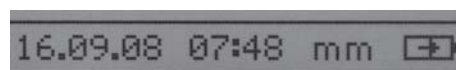

Description / Sequence

Symbols / Pictures

8.1.3 Exchanging the batteries

The battery can be changed without the height measuring instrument losing data (except for the time and date).

- Switch OFF the height measuring instrument
- Disconnect the charging device from the height measuring instrument
- Remove the battery cover, by unscrewing the 2 knurled thumb screws, ill. 1
- Carefully remove the battery pack out off the retaining spring (clips), ill. 2
- Press the new battery pack into the retaining spring and reconnect the plug to the battery pack, ill. 4
- Replace the battery cover and insert and tighten the knurled thumb screws
- Attach the new battery pack to the mains adapter and charger for a min. 5 hours.

Attention

Please only use the specified battery pack!
Order no. 4429449 - NI-MH 4.8 V - 7000mAh (with 3 cables)

1



2



3



4



8.2 Troubleshooting

Height measuring instrument 816 CL

Problem	Reason	Solution
1. Probe travels to the base plate but does not confirm a zero point	The transport protection screw M5 to lock the slide (see Page 11) is still locked	Unscrew the M5 screw further (see Page.11) Obtain a new zero point
2. Height measuring instrument cannot be switched on or started, the air bearings do not function	Rechargeable battery is empty. Incorrect charger Switch the ON/OFF switch on the rear of the height measuring instrument to ON	Connect the mains adapter to the height measuring instrument and charge for min. 5 hours Description Mains adapter: Type FW 7555M/08 Exchange the rechargeable battery
3. Data transmission does not function.	Still does not transmit Incorrect settings Incorrect data connection cable	Implement settings in menu 5.1 Data transmission. Connect the correct connection cable (RS232 or USB) to the correct interface on the PC and the height measuring instrument.
4. Printing is not possible	Incorrect settings Check the printer Printer is not connected	Implement settings in menu 4.2.1 Data and printer. Insert paper, check whether there is a paper blockage and if so remove paper. Use a RS232 data connection cable
5. Repetitive accuracy is outside of the tolerance.	Improper contacting (impact) Probe / work piece is dirty Variation in temperature Probe incorrectly calibrated Not a standard probe Probe is not sufficiently clamped in mount Battery is almost empty	Re-calibrate the probe Clean the probe / work piece Conduct measurements in an acclimatized room Switch on temperature compensation Check charge status of the battery, if necessary recharge
6. Ref.-Error	The probe cannot traverse the reference point	Remove the obstacle

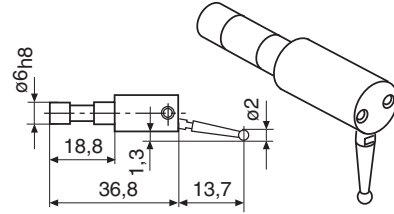
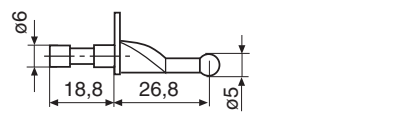
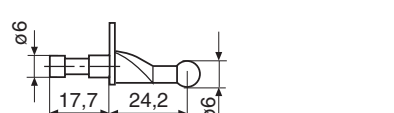
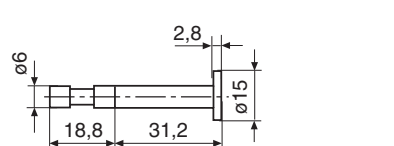
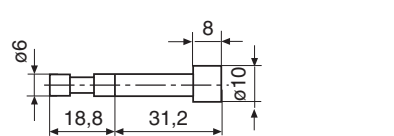
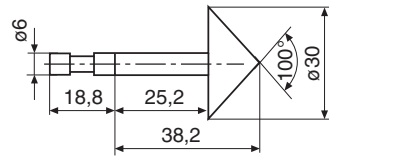
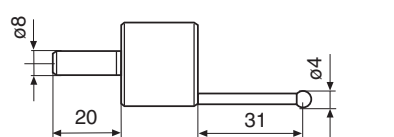
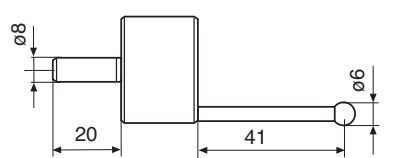
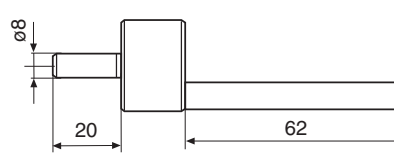
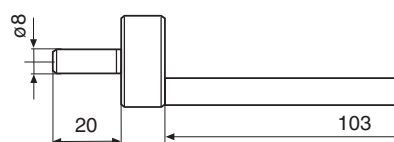

9 Accessories

	Type	Weight	Order no.
	Probe KM2 complete	15 g (.529 oz)	4429256
	Probe K5/51	15 g (.529 oz)	4429158
	Probe K6/51	15 g (.529 oz)	4429254
	Disc probe S15/31,2	15 g (.529 oz)	4429226
	Cylindrical probe Z10/31,2	15 g (.529 oz)	4429227
	Taper probe MKe 30	25 g (.881 oz)	4429228
	Spherical probe K4/30	102g (3.597 oz)	7023813
	Spherical probe K6/40	102g (3.597 oz)	7023816
	Spherical probe K10/60	102 g (3.597 oz)	7023810
	Spherical probe K10/100	102g (3.597 oz)	7023615

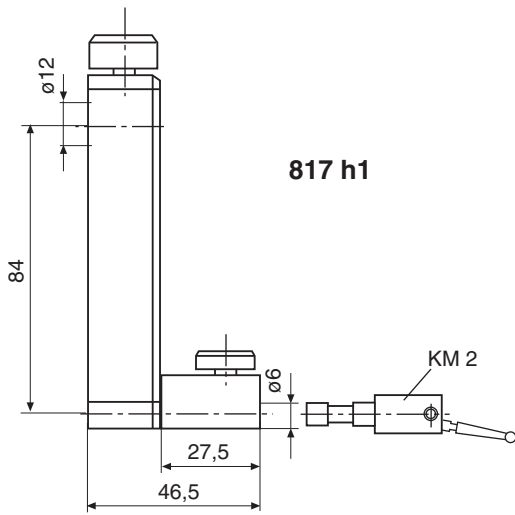

817 h1

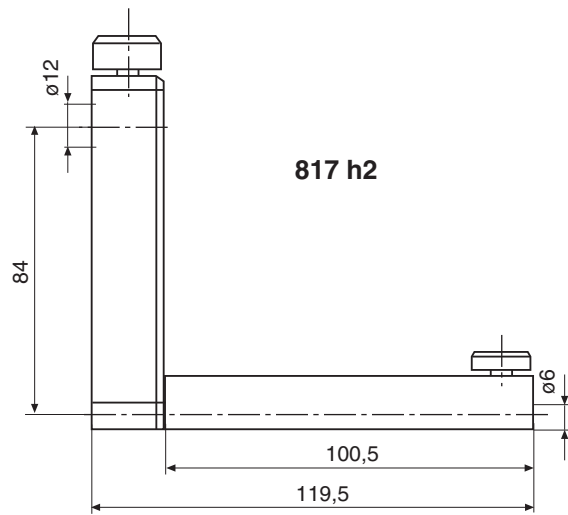

817 h2

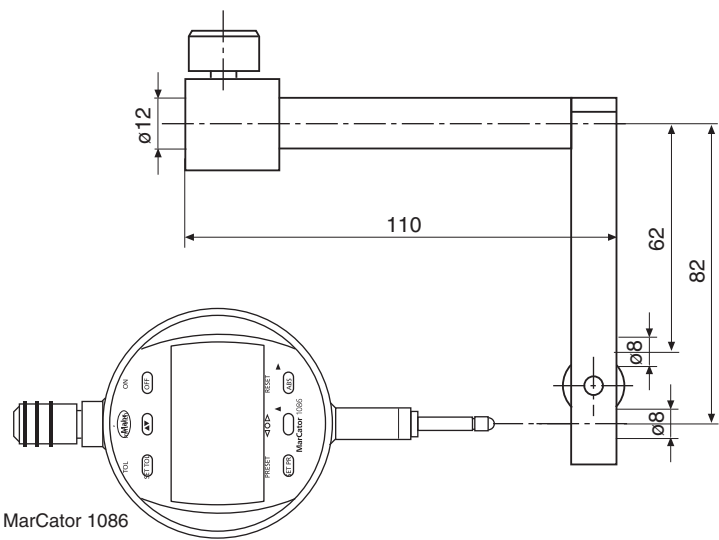

MarCator 1086

817 h3

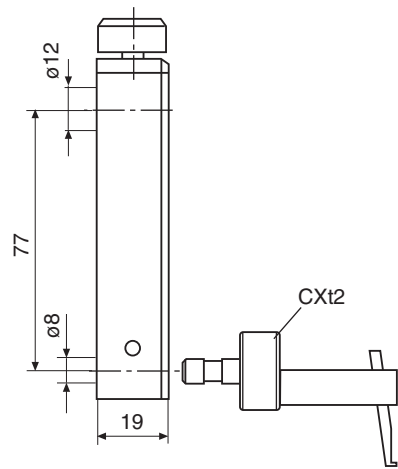

817 h4

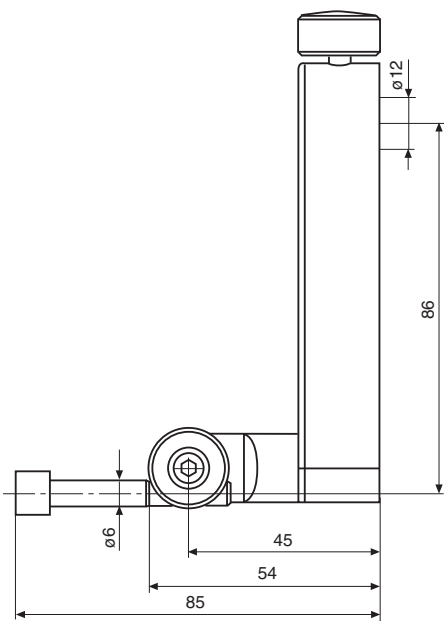

817 h5

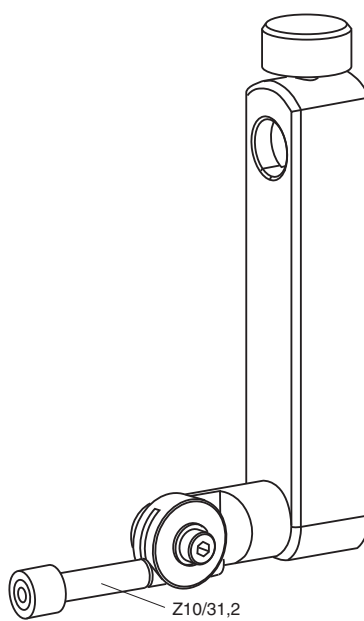

Z10/31,2

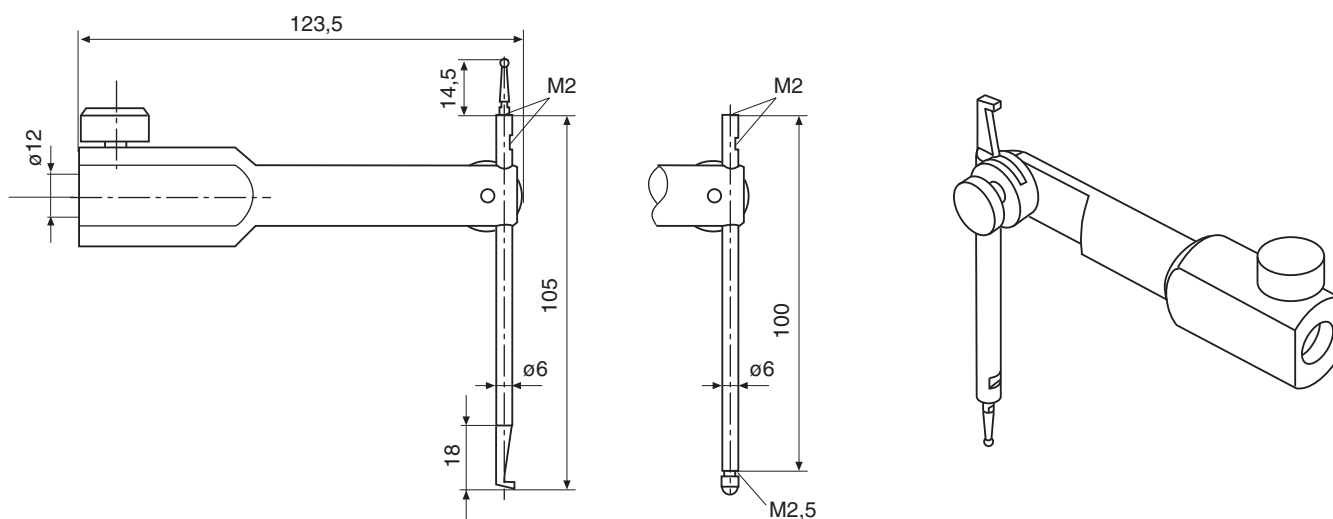

TMT 120 S

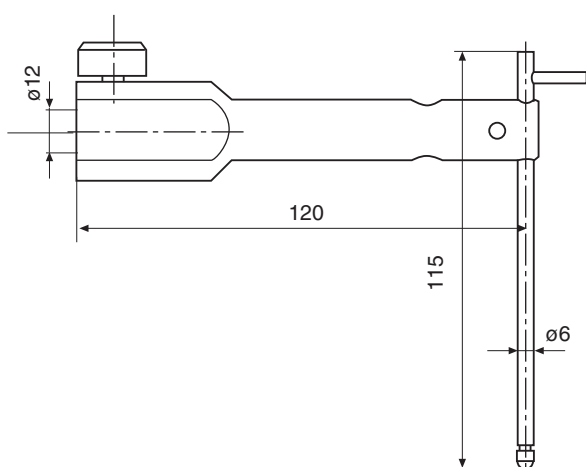

TMT 120

Catalog no.	Type	Weight	Order no.
817 h1	Standard probe carrier (without probe)	318 g (11.217 oz)	4429154
817 h2	Probe carrier 100 mm	318 g (11.217 oz)	4429219
817 h3	Digital indicator carrier	218 g (7.689 oz)	4429206
	Incremental probe	115 g (4.056 oz)	5315140
	MarCator 1086 / 12.5 mm	130 g (4.585 oz)	4337020
817 h4	Probe carrier K4/30-K10/100	231g (8.148 oz)	4429220
817 h5	Probe carrier with a joint (without probe)	318 g (11.217 oz)	4429454
TMT 120 S	Spherical probe (for depth) M2.5 / M2	333g (11.746 oz)	4429421
TMT 120	Spherical probe (for depth) M2.5 / M2	333g 11.746 oz)	4429221

Accessories Set 817 t1 in a case 4429019

Consists of:

Probe KM2 complete	4429256
Disc probe S15/31,2	4429226
Cylindrical probe Z10/31,2	4429227
Taper probe MKe 30	4429228
TMT 120 Spherical probe (depth) M2.5 / M2	4429221
817h2 Probe carrier 100 mm (3.9370 inch)	4429219
817h4 Probe carrier for K4/30-K10/100	4429220
Spherical probes K4/30	7023813
Spherical probes K6/40	7023816
Spherical probes K10/60	7023810
Spherical probes K10/100	7023615

Accessories Set 817 t2 in a case 4429018

Consists of:

Probe KM2 complete	4429256
Disc probe S15/31,2	4429226
Cylindrical probe Z10/31,2	4429227
Taper probe MKe 30	4429228
TMT 120 Spherical probe (depth) M2.5 / M2	4429221
817h2 Probe carrier 100 mm (3.9370 inch)	4429219



Accessories Set 817 ts1

Universal probe set CXt2 7034000

consists of:

Carrying case	3015925
Probe carrier	3015917

Dimension

Measuring crook	d = 0.5 mm (.0197 inch)
Pin probe/-tip:	ød = 1.2 mm (.0472 inch)

Shaft length

l = 78 mm (3.0708 inch)	3015918
l = 75 mm (2.9527 inch)	3015919
ls = 15.5 mm (.6102 inch)	

Taper probe	ød = 0-7.5 mm (0-.2952 inch)	3015920
Spherical probe	TC-ødk = 3 mm (.1181 inch)	3022000
Spherical probe	TC-ødk = 2 mm (.0787 inch)	3022001
Spherical probe	TC-ødk = 1 mm (.0393 inch)	3022002
Extension M3 - M3	d = 4 mm (.1574 inch)	3015921
Extension M3 - M2.5	d = 4 mm (.1574 inch)	3015888

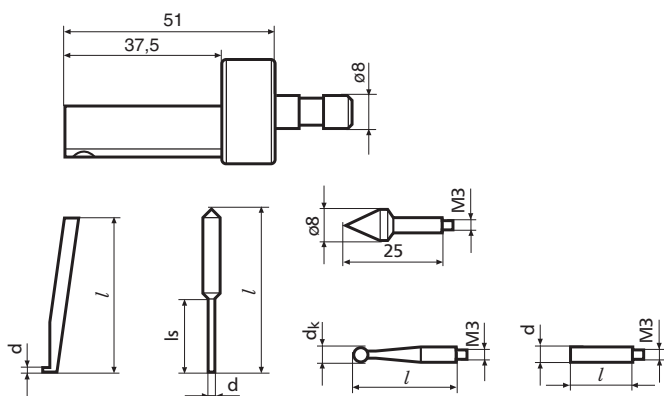

Universal probe set CXt2
in conjunction with probe carrier 817h4

Order no.

Software MarCom Standard	4102551
Software MarCom Professional	4102552
Digital indicator MarCator 1086 12.5 mm / 0,001	4337020
Spare battery 4.8V 7000mAh NiMh	4862931
800 a6 Mounting shaft for MarTest	4301865

Order no.

Mains power plug EURO FW 7555M/08	4102766
Adapter UK 1717618	9101328
Adapter US 1717715	4102778
MSP 2 Statistics printer	4102040
Data cable 2000 usb incl. MarCom Standard	4346023
Data cable 2000r Opto RS232	4346020

10 Technical data

Height measuring instrument 816 CL

Measuring range	350 mm 14"	600 mm 24"
Measuring (application) range extended	respectively ca. 170 mm / 7"	
Resolution	0.001, 0.01 (mm) 0.00005, 0.0001 (inch)	
Measuring error (20 °C, base plate according to DIN 876 /0, Probe K6/51, 6,0 mm)	2.8 + L/300 (L in mm)	
Perpendicularity error mechanic	≤15µm	≤20µm
Repeatability +/- 2 δ	on a plane: 2µm / in a bore: 3µm	
Measuring force	1 N +/- 0.2 N	
Contacting speeds	5, 8, 11, 15 mm/sec	
Max. permissible manual positioning of the measuring carriage	600 mm/s	
Drive mechanism	motorized	
3-point air cushion	ca. 9 µm	
Compressed air supply	integrated compressor	
Interchangeable probes	see accessories	
Vertical measuring system of the column	incremental measuring system	
Working- / operating temperature	10 °C ... 40 °C (50°F... 104 °F)	
Storage temperature	-10 °C...60 °C (14°F... 140 °F)	
Permissible relative humidity (operating)	max. 65% (non-condensing)	
Permissible relative humidity (storage)	max. 65 % (non-condensing)	
Weight	25 kg (55.16 lbs)	30 kg (66.14 lbs)
Operating time with charged battery *	up to 10 hours (depending on operation)	
Power supply	mains adapter 7,5V DC, Type FW 7555M/08	
Mains voltage / mains frequency	110V – 230V AC, 50-60 Hz	
Protection class	IP 40	
Keypad	membrane keypad with defined pressure points, IP67	
Interface	Opto RS232 duplex / USB	
Dimensions (D x W x H)	350 mm x 280 mm x 730 mm 14" x 11" x 29"	350 mm x 280 mm x 980 mm 14" x 11" x 39"

* When using the air bearings (cushion) the operating time of the battery will be reduced.

11 Alphabetical index

Term	Page	Term	Page
A			
ABS	30	E	
Absolute zero point	3, 30	Eccentric	20, 28, 32-34
Accessories	4, 55, 59	Enter a PRESET value	3, 25, 26
Accuracy	52	Exchanging a probe	22, 33
Acoustic signal	16, 18, 22, 23, 27	Expanding the measuring range	3, 26
Adapter	36, 38, 46, 58	F	
Additional functions	4, 49	Factory settings	4, 16, 44-45
Air bearings	13, 19, 52, 54, 59	FCT	29-34
Alphabetical index	4, 60	First steps	3, 18
Application range	59	Function keys	3, 14-17, 24, 29
B			
Base plate	2, 3, 18-19, 24-26, 30, 48, 52, 54, 59	G	
Basic settings	4, 37, 44	Gage block	22, 26
Basic-zero point, base plate	3, 25	Groove	3, 15, 16, 17, 19, 22, 27
Battery charger	13, 52	H	
Baud rate	38	Height measuring instrument	1-3, 13, 44, 46-49, 53-54, 59
Beep	16, 18, 22, 23, 27	Humidity	59
Bore	3, 15-17, 20, 28, 33, 47, 48, 59	I	
C			
Calibrating a probe	15, 23-24, 47	Inch	4, 14, 16, 38-39, 41, 43, 51, 59
Calibration	3, 16, 19, 22-24	Interface	2, 13, 36, 38, 46, 49, 54
Cancel	16, 24, 27, 41, 48	K	
Care	4, 52	Keypad	3, 13-14, 24-28, 30-34
CE	31, 35, 36, 41, 48	L	
Centre of a bore	3, 33	LED	13, 52
Charging the batteries	52	Ledge	3, 15-17, 22-23, 32
Cleaning	2, 4, 52	List of measured values	14, 35, 48
Coefficient of expansion	50	List of measurements	4, 17, 27, 35, 44-45
Coefficient of thermal expansion	50	List of results	16
Commissioning	3, 18	M	
Connection cable	36, 38, 46, 54	Mains	2, 18, 21, 38, 53, 54, 58, 59
Contacting from above	17, 31	Maintenance	4, 52
Contacting from below	17	MarCom	4, 38-39, 49, 58
Contacting parameter	4, 16, 43-44	Maximal	3, 16-17, 31, 33, 44, 47-48, 59
Contacting speed	4, 16, 42, 44, 59	Measured data	4, 39-40
Contact point	13,	Measured values	15, 36, 44
D			
DATA	36, 39, 40, 48	Measurement number	16, 38
Data connection cable	36, 38, 46, 54	Measuring force	59
Data transmission	4, 15-17, 36-40, 44, 49, 54	Measuring program	4, 15, 47-48
Date	4, 14, 14, 43, 45	Measuring range	59
Declaration of conformity	4, 62	Menu	4, 29-31, 36-37, 41, 44-45, 50, 54
Deflection	19, 22, 24	Min – Max function	16, 31, 44
Delete	4, 15, 35, 36, 41, 47-48		
Deviation	3, 24		
Disc probe	23		
Display	3, 4, 13, 14, 20, 21, 27-32, 34, 44, 45, 50		
Distance	17		
Duplex	36, 38, 58		

Term	Page	Term	Page
Minimal	3, 16, 17, 31, 38, 44, 47, 48, 49, 53-54	Switch ON	3, 18, 51, 54
MSP 2	4, 36, 58	Symbols	3-4, 15ff
O		Symmetry	17, 29, 48
Operating instructions	1, 17	T	
Operating temperature	59	Taper probe	3, 16, 24, 33, 58
Opto	36, 38, 46, 54	Technical data	4, 59
P		Temperature	17, 50-51
PC	38, 39, 46, 54	Temperature compensation	4, 17, 50-51, 54
Perpendicularity error	59	Time	4, 14, 16, 43, 50, 53
Plane	3, 17, 20	Tone	16, 18, 22, 23, 27
Position	20, 23, 27-28, 32-34, 36, 48	Transfer parameter	38
Power supply	18, 21, 38, 59	Transport protection screw	13, 54
Preset	3, 15, 25-26, 36	Troubleshooting	4, 54
Print	4, 35-36, 54	U	
Printer	4, 36, 39, 54	Unit of measurement	14, 41, 43
Probe	3, 19, 22-25, 32-34, 54, 55ff	Universal probe set	58
Probe deflection	19, 22, 24	USB	38, 46, 49, 54, 58-59
Probe lift	1, 43, 44	V	
Program	17, 46-48	Variable function keys	14, 29
R		Voltage	2, 59
Rechargeable battery	2, 14, 52, 53, 54, 58, 59	W	
Record header	4, 37, 39, 40, 44	Warranty	2
Reference point	18, 25, 54	Weight	8, 22, 57, 59
Register	16	Working temperature	59
Relative	15, 29-30	Z	
Resolution	4, 16, 41, 44	Zero point	3, 15, 18, 24-26, 29-30, 48, 54
Return	4, 15, 16, 34, 41	Zero point on the base plate	3, 25
Reversal point	21, 28, 32-34		
RoHS	2		
RS232	36, 38, 46, 49, 54, 58		
S			
Safety instructions	2		
Scope of supply	3, 5		
Self help	4, 52		
Send	4, 17, 36, 37, 39		
Send a series of measuring data	4, 37, 39		
Service	4, 16, 44		
Set of accessories	58		
Setting standard	19, 22, 24		
Setting up	3, 5		
Shaft	3, 15-17, 32, 34		
Shaft	3, 15-17, 32, 34, 58		
Software	4, 36, 45-46, 58		
Software update	4, 36, 45-46		
Standstill-time	4, 16, 42, 44		
State of charge of the battery	52, 54		
Switch OFF	3, 21, 53		

12 Declaration of conformity



Konformitätserklärung

Declaration of Conformity / Déclaration de conformité / Atestado de conformidad / Dichiarazione di conformità

Wir	Mahr GmbH	erklären in alleiniger Verantwortung, dass das Produkt
We	Reutlingerstrasse 48	declare under our sole responsibility that the product
Nous	D- 73728 Esslingen	déclarons sous notre seule responsabilité que le produit
Nosotros	Germany	declaramos con responsabilidad exclusiva que el producto
Noi		dichiariamo con la responsabilità esclusiva che il prodotto

Bezeichnung: Höhenmessgerät
name: / nom: / nombre: / nome:

Typ: 816CL
type: / type: / tipo: / tipo:

ab Lieferdatum oder Serien-Nr.: 01.05.2009
from delivery date or serial number:
à partir de date de livraison ou n° de série:
a partir de fecha de entrega o núm. de serie:
da data di consegna o numero di serie:

gemäß der Richtlinien: - Niederspannungsrichtlinie 2006/95/EG
following the Directive(s): - Richtlinie über die elektromagnetische Verträglichkeit
conformément à la Directive: 2004/108/EG
con arreglo a la Directiva:
secondo alla Direttiva:

mit folgenden Normen übereinstimmt: - Sicherheitsbestimmungen für elektrische Messgeräte
is in conformity with the following standards: DIN EN 61010-1: 2001
est conforme aux normes: - Störfestigkeit Industriebereich EN 61000-6-2: 2005
está conforme con las normas siguientes: - Störaussendung Industriebereich EN 61000-6-4: 2007
è conforme alle norme seguenti:

Ort u. Datum: Esslingen, 29.1.2009

Unterschrift: 

Geschäftsleitung

Place and date:
Lieu et date:
Lugar y fecha:
Luogo e data:

Signature:
Signature:
Firma:
Firma:

Managing Director
Directeur Général
Gerente
Gerenza

Dokument-Id.-Nr.:
3755966